

WARRIOR III

PA-28-161

REFERENCE ONLY

THIS ELECTRONIC VERSION
OF THE POH IS
NOT APPROVED TO
REPLACE ANY OPERATING
INFORMATION REQUIRED
BY THE REGULATIONS.

PILOT'S OPERATING HANDBOOK

AND

FAA APPROVED AIRPLANE FLIGHT MANUAL

AIRPLANE
SERIAL NO. _____

AIRPLANE
REGIST. NO. _____

PA-28-161

REPORT: VB-1565 FAA APPROVED BY:



WILLIAM R. MOREU

D.O.A. NO. SO-1

PIPER AIRCRAFT CORPORATION

VERO BEACH, FLORIDA

DATE OF APPROVAL:
JULY 1, 1994

FAA APPROVED IN NORMAL AND UTILITY CATEGORIES BASED ON CAR 3.
THIS HANDBOOK INCLUDES THE MATERIAL REQUIRED TO BE FURNISHED TO
THE PILOT BY CAR 3 AND CONSTITUTES THE APPROVED AIRPLANE FLIGHT
MANUAL AND MUST BE CARRIED IN THE AIRPLANE AT ALL TIMES.



WARNING

EXTREME CARE MUST BE EXERCISED TO LIMIT THE USE OF THIS HANDBOOK TO APPLICABLE AIRCRAFT. THIS HANDBOOK IS VALID FOR USE WITH THE AIRPLANE IDENTIFIED ON THE FACE OF THE TITLE PAGE. SUBSEQUENT REVISIONS SUPPLIED BY PIPER AIRCRAFT CORPORATION MUST BE PROPERLY INSERTED.

Published by
PUBLICATIONS DEPARTMENT

Issued: JULY 1, 1994
© 1994, 1995, 2015
Piper Aircraft Corporation
All Rights Reserved

REPORT: VB-1565

ii

ISSUED: JULY 1, 1994
REVISED: JULY 17, 2015

APPLICABILITY

Application of this handbook is limited to the specific Piper PA-28-161 model airplane designated by serial number and registration number on the face of the title page of this handbook.

This handbook cannot be used for operational purposes unless kept in a current status.

REVISIONS

The information compiled in the Pilot's Operating Handbook, with the exception of the equipment list, will be kept current by revisions distributed to the airplane owners. The equipment list was current at the time the airplane was licensed by the manufacturer and thereafter must be maintained by the owner.

Revision material will consist of information necessary to update the text of the present handbook and/or to add information to cover added airplane equipment.

I. Revisions

Revisions will be distributed whenever necessary as complete page replacements or additions and shall be inserted into the handbook in accordance with the instructions given below:

1. Revision pages will replace only pages with the same page number.
2. Insert all additional pages in proper numerical order within each section.
3. Page numbers followed by a small letter shall be inserted in direct sequence with the same common numbered page.

II. Identification of Revised Material

Revised text and illustrations shall be indicated by a black vertical line along the outside margin of the page, opposite revised, added or deleted material. A line along the outside margin of the page opposite the page number will indicate that an entire page was added.

REPORT: VB-1565

iii

Black lines will indicate only current revisions with changes and additions to or deletions of existing text and illustrations. Changes in capitalization, spelling, punctuation or the physical location of material on a page will not be identified by symbols.

ORIGINAL PAGES ISSUED

The original pages issued for this handbook prior to revision are given below:



Title, ii through vii, 1-1 through 1-10, 2-1- through 2-9, 3-1 through 3-16, 4-1 through 4-25, 5-1 through 5-29, 6-1 through 6-17, 7-1 through 7-26, 8-1 through 8-18, 9-1 through 9-72 and 10-1 through 10-2.

REPORT: VB-1565

iv

PILOT'S OPERATING HANDBOOK LOG OF REVISIONS

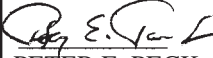
Current Revisions to the PA-28-161 WARRIOR III Pilot's Operating Hand-book, REPORT: VB-1565 issued JULY 1, 1994.

Revision Number and Code	Revised Pages	Description of Revisions	FAA Approval Signature and Date
Rev. 1 (PR950224)	v	Added Rev 1 to Log of Rev's.	 PETER E. PECK FAA/DOA Coordinator <u>JUNE. 9, 1995</u> Date
	5-3	Revised Para. 5.5 (note) (a) 1& 6	
	5-4	Revised Para. 5.5 (b) 5	
	5-5	Revised Para. 5.5 (c).3 & 4	
	5-6	Revised Para. 5.5 (d).1, 2, & 3 (e) 2	
	5-7	Revised Para. 5.5 (e), (f).& (g)	
	5-9	Revised Para. 5.7 List of Fig.	
	5-18	Added Fig. 5-15.	
	5-19	Revised Fig. 5-17.	
	5-20	Revised Fig. 5-19.	
	5-20b	Added Fig. 5-21.	
	5-21	Added Fig. 5-23.	
	5-22	Added Fig. 5-23a.	
	5-23	Added Fig. 5-23b.	
5-24	Added Fig. 5-25.		
5-25	Added Fig. 5-29 .		
5-26	Added Fig. 5-31.		
Rev. 2 (PR150717)	ii	Added copyright information.	 Eric A. Wright July 17, 2015
	v	Added Rev. 2 to L of R.	
	2-9	Revised Para. 2.25.	
	4-17	Revised Para. 4.13.	
	8-1	Revised Para. 8.1.	
	8-2	Revised Para. 8.1.	

ISSUED: JULY 1, 1994
REVISED: JULY 17, 2015

REPORT: VB-1565
 v

PILOT'S OPERATING HANDBOOK LOG OF REVISIONS

Revision Number and Code	Revised Pages	Description of Revisions	FAA Approval Signature and Date

TABLE OF CONTENTS

SECTION 1	GENERAL
SECTION 2	LIMITATIONS
SECTION 3	EMERGENCY PROCEDURES
SECTION 4	NORMAL PROCEDURES
SECTION 5	PERFORMANCE
SECTION 6	WEIGHT AND BALANCE
SECTION 7	DESCRIPTION AND OPERATION OF THE AIRPLANE AND ITS SYSTEMS
SECTION 8	AIRPLANE HANDLING, SERVICING AND MAINTENANCE
SECTION 9	SUPPLEMENTS
SECTION 10	OPERATING TIPS

THIS PAGE INTENTIONALLY LEFT BLANK

REPORT: VB-1565
viii

TABLE OF CONTENTS

SECTION 1

GENERAL

Paragraph No.		Page No.
1.1	Introduction	1-1
1.3	Engines	1-3
1.5	Propellers.....	1-3
1.7	Fuel.....	1-3
1.9	Oil.....	1-4
1.11	Maximum Weights	1-4
1.13	Standard Airplane Weight	1-4
1.15	Baggage Space	1-4
1.17	Specific Loadings	1-4
1.19	Symbols, Abbreviations and Terminology	1-5

THIS PAGE INTENTIONALLY LEFT BLANK

SECTION 1

GENERAL

1.1 INTRODUCTION

This Pilot's Operating Handbook is designed for maximum utilization as an operating guide for the pilot. It includes the material required to be furnished to the pilot by the FAR/CAR. It also contains supplemental data supplied by the airplane manufacturer.

This handbook is not designed as a substitute for adequate and competent flight instruction, knowledge of current airworthiness directives, applicable federal air regulations or advisory circulars. It is not intended to be a guide for basic flight instruction or a training manual and should not be used for operational purposes unless kept in a current status.

Assurance that the airplane is in an airworthy condition is the responsibility of the owner. The pilot in command is responsible for determining that the airplane is safe for flight. The pilot is also responsible for remaining within the operating limitations as outlined by instrument markings, placards, and this handbook.

Although the arrangement of this handbook is intended to increase its in-flight capabilities, it should not be used solely as an occasional operating reference. The pilot should study the entire handbook to familiarize himself with the limitations, performance, procedures and operational handling characteristics of the airplane before flight.

The handbook has been divided into numbered (arabic) sections, each provided with a finger-tip tab divider for quick reference. The limitations and emergency procedures have been placed ahead of the normal procedures, performance and other sections to provide easier access to information that may be required in flight. The Emergency Procedures Section has been furnished with a red tab divider to present an instant reference to the section. Provisions for expansion of the handbook have been made by the deliberate omission of certain paragraph numbers, figure numbers, item numbers and pages noted as being intentionally left blank.

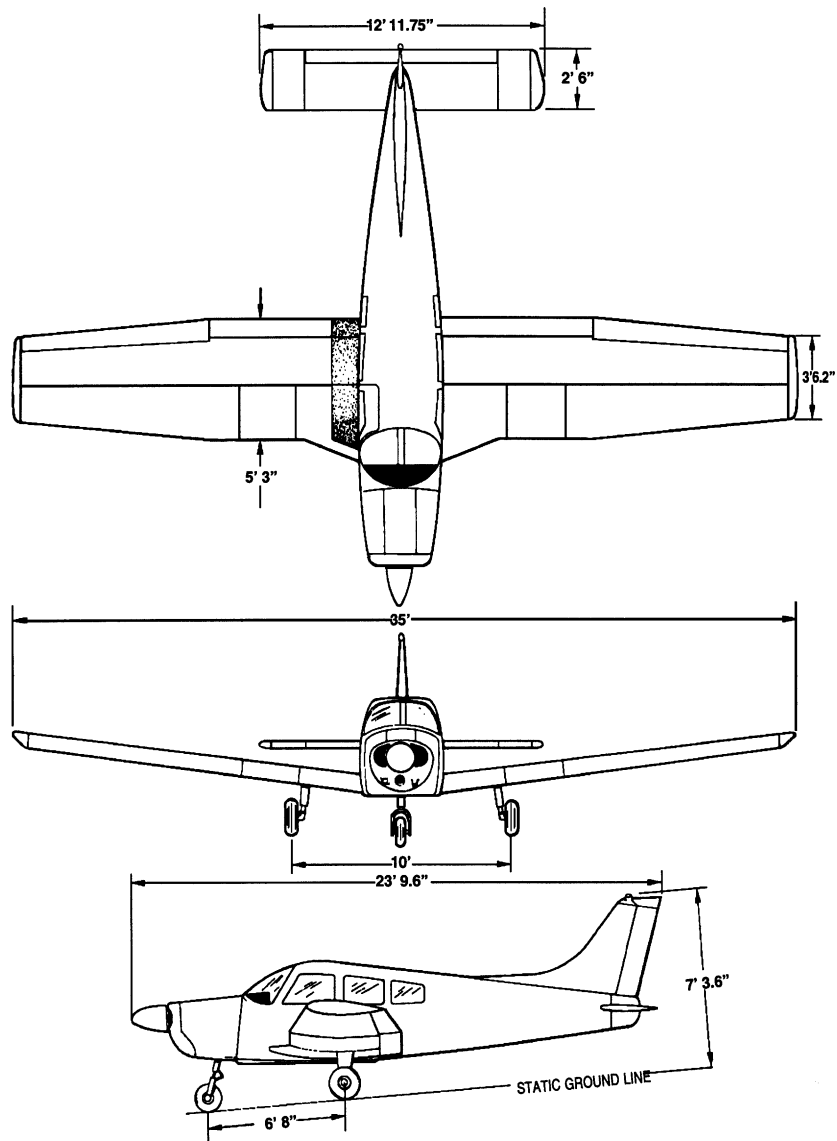

THREE VIEW
Figure 1-1

1.3 ENGINES

(a) Number of Engines	1
(b) Engine Manufacturer	Lycoming
(c) Engine Model Number	O-320-D3G
(d) Rated Horsepower	160
(e) Rated Speed (rpm)	2700
(f) Bore (inches)	5.125
(g) Stroke (inches)	3.875
(h) Displacement (cubic inches)	319.8
(i) Compression Ratio	8.5:1
(j) Engine Type	Four Cylinder, Direct Drive, Horizontally Opposed, Air Cooled

1.5 PROPELLERS

(a) Number of Propellers	1
(b) Propeller Manufacturer	Sensenich
(c) Model	74DM6-0-60
(d) Number of Blades	2
(e) Propeller Diameter (inches)	
(1) Maximum	74
(2) Minimum	72
(f) Propeller Type	Fixed Pitch

1.7 FUEL

AVGAS ONLY

(a) Fuel Capacity (U.S. gal) (total)	50
(b) Usable Fuel (U.S. gal) (total)	48
(c) Fuel	
(1) Minimum Octane	100 Green or 100LL Blue Aviation Grade
(2) Alternate Fuel	Refer to Fuel Requirements, Section 8 - Handling, Servicing and Maintenance.

**SECTION 1
GENERAL**

**PIPER AIRCRAFT CORPORATION
PA-28-161, WARRIOR III**

1.9 OIL

- | | | |
|---|-----------|---|
| (a) Oil Capacity (U.S. quarts) | | 8 |
| (b) Oil Specification | | Refer to latest issue
of Lycoming Service
Instruction 1014. |
| (c) Oil Viscosity per Average Ambient
Temp. for Starting | | |
| | Single | Multi |
| (1) Above 60°F | S.A.E. 50 | S.A.E. 40 or 50 |
| (2) 30°F to 90°F | S.A.E. 40 | S.A.E. 40 |
| (3) 0°F to 70°F | S.A.E. 30 | S.A.E. 40 or
20W-30 |
| (4) Below 10°F | S.A.E. 20 | S.A.E. 20W-30 |

1.11 MAXIMUM WEIGHTS

- | | | |
|--|--------|---------|
| | Normal | Utility |
| (a) Maximum Takeoff Weight (lbs) | 2440 | 2020 |
| (b) Maximum Ramp Weight (lbs) | 2447 | 2027 |
| (c) Maximum Landing Weight (lbs) | 2440 | 2020 |
| (d) Maximum Weight in Baggage
Compartment (lbs) | 200 | 0 |

1.13 STANDARD AIRPLANE WEIGHTS

Refer to Figure 6-5 for the Standard Empty Weight and the Useful Load.

1.15 BAGGAGE SPACE

- | | |
|-------------------------------------|----|
| (a) Compartment Volume (cubic feet) | 24 |
|-------------------------------------|----|

1.17 SPECIFIC LOADINGS

- | | |
|----------------------------------|------|
| (a) Wing Loading (lbs per sq ft) | 14.4 |
| (b) Power Loading (lbs per hp) | 15.3 |

1.19 SYMBOLS, ABBREVIATIONS AND TERMINOLOGY

The following definitions are of symbols, abbreviations and terminology used throughout the handbook and those which may be of added operational significance to the pilot.

(a) General Airspeed Terminology and Symbols

CAS	Calibrated Airspeed means the indicated speed of an aircraft, corrected for position and instrument error. Calibrated airspeed is equal to true airspeed in standard atmosphere at sea level.
KCAS	Calibrated Airspeed expressed in Knots.
GS	Ground Speed is the speed of an airplane relative to the ground.
IAS	Indicated Airspeed is the speed of an aircraft as shown on the airspeed indicator when corrected for instrument error. IAS values published in this handbook assume zero instrument error.
KIAS	Indicated Airspeed expressed in Knots.
M	Mach Number is the ratio of true airspeed to the speed of sound.
TAS	True Airspeed is the airspeed of an airplane relative to undisturbed air which is the CAS corrected for altitude, temperature and compressibility.
V _A	Maneuvering Speed is the maximum speed at which application of full available aerodynamic control will not overstress the airplane.
V _{FE}	Maximum Flap Extended Speed is the highest speed permissible with wing flaps in a prescribed extended position.

**SECTION 1
GENERAL**

**PIPER AIRCRAFT CORPORATION
PA-28-161, WARRIOR III**

V _{NE} /M _{NE}	Never Exceed Speed or Mach Number is the speed limit that should not be exceeded at any time.
V _{NO}	Maximum Structural Cruising Speed is the speed that should not be exceeded except in smooth air and then only with caution.
V _S	Stalling Speed or the minimum steady flight speed at which the airplane is controllable.
V _{SO}	Stalling Speed or the minimum steady flight speed at which the airplane is controllable in the landing configuration.
V _X	Best Angle-of-Climb Speed is the airspeed which delivers the greatest gain of altitude in the shortest possible horizontal distance.
V _Y	Best Rate-of-Climb Speed is the airspeed which delivers the greatest gain in altitude in the shortest possible time.

(b) Meteorological Terminology

ISA	International Standard Atmosphere in which: The air is a dry perfect gas; The temperature at sea level is 15 Celsius (59 Fahrenheit); The pressure at sea level is 29.92 inches Hg (1013.2 mb); The temperature gradient from sea level to the altitude at which the temperature is -56.5C (-69.7F) is -0.00198C (-0.003564F) per foot and zero above that altitude.
OAT	Outside Air Temperature is the free air static temperature obtained either from inflight temperature indications or ground meteorological sources, adjusted for instrument error and compressibility effects.

Indicated Pressure Altitude	The number actually read from an altimeter when the barometric subscale has been set to 29.92 inches of mercury (1013.2 millibars).
Pressure Altitude	Altitude measured from standard sea-level pressure (29.92 in. Hg) by a pressure or barometric altimeter. It is the indicated pressure altitude corrected for position and instrument error. In this handbook, altimeter instrument errors are assumed to be zero.
Station Pressure	Actual atmospheric pressure at field elevation.
Wind	The wind velocities recorded as variables on the charts of this handbook are to be understood as the headwind or tailwind components of the reported winds.

(c) Power Terminology

Takeoff Power	Maximum power permissible for takeoff.
Maximum Continuous Power	Maximum power permissible continuously during flight.
Maximum Climb Power	Maximum power permissible during climb.
Maximum Cruise Power	Maximum power permissible during cruise.

(d) Engine Instruments

EGT Gauge	Exhaust Gas Temperature Gauge
-----------	-------------------------------

(e) Airplane Performance and Flight Planning Terminology

Climb Gradient	The demonstrated ratio of the change in height during a portion of a climb, to the horizontal distance traversed in the same time interval.
Demonstrated Crosswind Velocity	The demonstrated crosswind velocity is the velocity of the crosswind component for which adequate control of the airplane during takeoff and landing was actually demonstrated during certification tests.
Accelerate-Stop Distance	The distance required to accelerate an airplane to a specified speed and, assuming failure of an engine at the instant that speed is attained, to bring the airplane to a stop.
Route Segment	A part of a route. Each end of that part is identified by (1) a geographical location or (2) a point at which a definite radio fix can be established.

(f) Weight and Balance Terminology

Reference Datum	An imaginary vertical plane from which all horizontal distances are measured for balance purposes.
Station	A location along the airplane fuselage usually given in terms of distance from the reference datum.
Arm	The horizontal distance from the reference datum to the center of gravity (C.G.) of an item.

Moment	The product of the weight of an item multiplied by its arm. (Moment divided by a constant is used to simplify balance calculations by reducing the number of digits.)
Center of Gravity (C.G.)	The point at which an airplane would balance if suspended. Its distance from the reference datum is found by dividing the total moment by the total weight of the airplane.
C.G. Arm	The arm obtained by adding the airplane's individual moments and dividing the sum by the total weight.
C.G. Limits	The extreme center of gravity locations within which the airplane must be operated at a given weight.
Usable Fuel	Fuel available for flight planning.
Unusable Fuel	Fuel remaining after a runout test has been completed in accordance with governmental regulations.
Standard Empty Weight	Weight of a standard airplane including unusable fuel, full operating fluids and full oil.
Basic Empty Weight	Standard empty weight plus optional equipment.
Payload	Weight of occupants, cargo and baggage.
Useful Load	Difference between takeoff weight, or ramp weight if applicable, and basic empty weight.
Maximum Ramp Weight	Maximum weight approved for ground maneuver. (It includes weight of start, taxi and run up fuel.)

**SECTION 1
GENERAL**

**PIPER AIRCRAFT CORPORATION
PA-28-161, WARRIOR III**

Maximum
Takeoff Weight

Maximum weight approved for the start
of the takeoff run.

Maximum
Landing Weight

Maximum weight approved for the landing
touchdown.

Maximum Zero
Fuel Weight

Maximum weight exclusive of usable fuel.

TABLE OF CONTENTS

SECTION 2

LIMITATIONS

Paragraph No.		Page No.
2.1	General	2-1
2.3	Airspeed Limitations	2-1
2.5	Airspeed Indicator Markings.....	2-2
2.7	Power Plant Limitations	2-2
2.9	Power Plant Instrument Markings.....	2-3
2.11	Weight Limits	2-4
2.13	Center of Gravity Limits	2-5
2.15	Maneuver Limits	2-5
2.17	Flight Load Factors	2-6
2.19	Kinds of Operation Equipment List	2-6
2.21	Fuel Limitations	2-7
2.25	Placards	2-8

THIS PAGE INTENTIONALLY LEFT BLANK

REPORT: VB-1565

2-ii

**SECTION 2
LIMITATIONS**

2.1 GENERAL

This section provides the FAA Approved operating limitations, instrument markings, color coding and basic placards necessary for operation of the airplane and its systems.

This airplane must be operated as a normal or utility category airplane in compliance with the operating limitations stated in the form of placards and markings and those given in this section and handbook.

Limitations associated with those optional systems and equipment which require handbook supplements can be found in Section 9 (Supplements).

2.3 AIRSPEED LIMITATIONS

SPEED	KIAS	KCAS
Never Exceed Speed (VNE) - Do not exceed this speed in any operation.	160	153
Maximum Structural Cruising Speed (VNO) - Do not exceed this speed except in smooth air and then only with caution.	126	122
Maximum Flaps Extended Speed (VFE) - Do not exceed this speed with the flaps extended.	103	100

**SECTION 2
LIMITATIONS**

**PIPER AIRCRAFT CORPORATION
PA-28-161, WARRIOR III**

SPEED	KIAS	KCAS
Design Maneuvering Speed (VA) - Do not make full or abrupt control movements above this speed.		
At 2440 LBS. G.W.	111	108
At 1531 LBS. G.W.	88	89

CAUTION

Maneuvering speed decreases at lighter weight as the effects of aerodynamic forces become more pronounced. Linear interpolation may be used for intermediate gross weights. Maneuvering speed should not be exceeded while operating in rough air.

2.5 AIRSPEED INDICATOR MARKINGS

MARKING	KIAS
Red Radial Line (Never Exceed)	160
Yellow Arc(Caution Range - Smooth Air Only)	126 to 160
Green Arc (Normal Operating Range)	50 to 126
White Arc (Flap Down)	44 to 103

2.7 POWER PLANT LIMITATIONS

(a) Number of Engines	1
(b) Engine Manufacturer	Lycoming
(c) Engine Model No.	O-320-D3G
(d) Engine Operating Limits	
(1) Maximum Horsepower	160
(2) Maximum Rotation Speed (RPM)	2700
(3) Maximum Oil Temperature	245°F
(e) Oil Pressure	
Minimum (red line)	25 PSI
Maximum (red line)	115 PSI
(f) Fuel Pressure	
Minimum (red line)	.5 PSI
Maximum (red line)	8 PSI
(g) Fuel (AVGAS ONLY) (minimum grade)	100 or 100LL Aviation Grade

(h) Number of Propellers	1
(i) Propeller Manufacturer	Sensenich
(j) Propeller Model	74DM6-0-60
(k) Propeller Diameter	
Minimum	72 IN.
Maximum	74 IN.
(l) 74DM6-0-60 Propeller Tolerance (static rpm at maximum permissible throttle setting, Sea Level, ISA)	Not above 2430 RPM Not below 2330 RPM

NOTE

Refer to the airplane maintenance manual for test procedure to determine approved static rpm under non standard conditions.

NOTE

Refer to the airplane maintenance manual for test procedure to determine approved static rpm under non standard conditions.

2.9 POWER PLANT INSTRUMENT MARKINGS

(a) Tachometer	
Green Arc (Normal Operating Range)	500 to 2700 RPM
Red Line (Maximum Continuous Power)	2700 RPM
(b) Oil Temperature	
Green Arc (Normal Operating Range)	100° to 245°F
Red Line (Maximum)	245°F

**SECTION 2
LIMITATIONS**

**PIPER AIRCRAFT CORPORATION
PA-28-161, WARRIOR III**

2.9 POWER PLANT INSTRUMENT MARKINGS (Continued)

(c) Oil Pressure		
Green Arc (Normal Operating Range)		55 to 90 PSI
Yellow Arc (Caution Range) (Idle)		25 to 55 PSI
Yellow Arc (Ground Warm-Up)		95 to 115 PSI
Red Line (Minimum)		25 PSI
Red Line (Maximum)		115 PSI
(d) Fuel Pressure		
Green Arc (Normal Operating Range)		.5 to 8 PSI
Red Line (Minimum)		.5 PSI
Red Line (Maximum)		8 PSI

2.11 WEIGHT LIMITS

	Normal	Utility
(a) Maximum Weight	2440 LBS	2020 LBS
(b) Maximum Ramp Weight	2447 LBS	2027 LBS
(c) Maximum Baggage	200 LBS	0 LBS

NOTE

Refer to Section 5 (Performance) for maximum weight as limited by performance.

2.13 CENTER OF GRAVITY LIMITS

(a) Normal Category

Weight Pounds	Forward Limit Inches Aft of Datum	Rearward Limit Inches Aft of Datum
2440	88.3	93.0
1950 (and less)	83.0	93.0

(b) Utility Category

Weight Pounds	Forward Limit Inches Aft of Datum	Rearward Limit Inches Aft of Datum
1950 (and less)	83.0	93.0
2020	83.8	93.0

NOTES

Straight line variation between points given.

The datum used is 78.4 inches ahead of the wing leading edge at the inboard intersection of the straight and tapered section.

It is the responsibility of the airplane owner and the pilot to insure that the airplane is properly loaded. See Section 6 (Weight and Balance) for proper loading instructions.

2.15 MANEUVER LIMITS

- (a) Normal Category - All acrobatic maneuvers including spins prohibited.
- (b) Utility Category - Approved Maneuvers for bank angles exceeding 60°:

	Entry Speed
Steep Turns	111 KIAS
Lazy Eights	111 KIAS
Chandelles	111 KIAS

**SECTION 2
LIMITATIONS**

**PIPER AIRCRAFT CORPORATION
PA-28-161, WARRIOR III**

2.17 FLIGHT LOAD FACTORS

	Normal	Utility
(a) Positive Load Factor (Maximum)	3.8 G	4.4 G
(b) Negative Load Factor (Maximum)	No inverted maneuvers approved	

2.19 KINDS OF OPERATION EQUIPMENT LIST

This airplane may be operated in day or night VFR, day or night IFR when the appropriate equipment is installed and operable.

The following equipment list identifies the systems and equipment upon which type certification for each kind of operation was predicated and must be installed and operable for the particular kind of operation indicated. However, certain operations may be authorized with certain listed equipment and/or systems inoperative under certain conditions and under provisions defined by a current Minimum Equipment List (MEL) approved by the FAA which is dated concurrently with or after this Pilot's Operating Handbook and FAA Approved Airplane Flight Manual and authorized under an operating regulation which provides for use of an MEL.

- (a) Day VFR
 - (1) Airspeed indicator
 - (2) Altimeter
 - (3) Magnetic compass
 - (4) Tachometer
 - (5) Oil pressure indicator
 - (6) Oil temperature indicator
 - (7) Fuel pressure indicator
 - (8) Fuel quantity indicator - each tank
 - (9) Volt-ammeter
 - (10) Elevator/rudder trim indicator
 - (11) Alternator
 - (12) Safety restraint - each occupant
- (b) Night VFR
 - (1) All equipment required for Day VFR
 - (2) Position lights
 - (3) Instrument lights
 - (4) Anti-collision (strobe) lights

- (c) Day IFR
 - (1) All equipment required for Day VFR
 - (2) Vacuum pump
 - (3) Gyro suction indicator

- (d) Night IFR
 - (1) All equipment required for Day and Night VFR
 - (2) All equipment required for Day IFR

NOTE

The above system and equipment list does not include specific flight instruments and communication/navigation equipment required by the FAR Part 91 and 135 operating requirements.

2.21 FUEL LIMITATIONS

- (a) Total Capacity 50 U.S. GAL
- (b) Unusable Fuel 2 U.S. GAL
The unusable fuel for this airplane has been determined as 1.0 gallon in each wing in critical flight attitudes.
- (c) Usable Fuel 48 U.S. GAL
The usable fuel in this airplane has been determined as 24.0 gallons in each wing.

2.25 PLACARDS

In full view of the pilot:

THIS AIRPLANE MUST BE OPERATED AS A NORMAL OR UTILITY CATEGORY AIRPLANE IN COMPLIANCE WITH THE OPERATING LIMITATIONS STATED IN THE FORM OF PLACARDS, MARKINGS AND MANUALS.

ALL MARKINGS AND PLACARDS ON THIS AIRPLANE APPLY TO ITS OPERATION AS A UTILITY CATEGORY AIRPLANE. FOR NORMAL AND UTILITY CATEGORY OPERATION, REFER TO THE PILOT'S OPERATING HANDBOOK.

NO ACROBATIC MANEUVERS ARE APPROVED FOR NORMAL CATEGORY OPERATIONS. SPINS ARE PROHIBITED FOR NORMAL AND UTILITY CATEGORY.

In full view of the pilot:

TAKEOFF CHECKLIST

Fuel on proper tank	Seat backs erect
Electric fuel pump on	Fasten belts/harness
Engine gauges checked	Trim tab - set
Flaps - set	Controls - free
Carb. heat off	Door - latched
Mixture set	

LANDING CHECKLIST

Fuel on proper tank	Flaps - set (White Arc)
Mixture rich	Fasten belts/harness
Electric fuel pump on	
Seat backs erect	

Adjacent to upper door latch:

ENGAGE LATCH BEFORE FLIGHT

On inside of the baggage compartment door:

BAGGAGE MAXIMUM 200 LBS
UTILITY CATEGORY OPERATION — NO BAGGAGE
OR AFT PASSENGERS ALLOWED. NORMAL
CATEGORY OPERATION - SEE PILOT'S OPER-
ATING HANDBOOK WEIGHT AND BALANCE
SECTION FOR BAGGAGE AND AFT PASSENGER
LIMITATIONS.

In full view of the pilot:

$V_A = 111$ KIAS AT 2440# (SEE P.O.H.)

UTILITY CATEGORY OPERATION - NO AFT
PASSENGERS ALLOWED.

DEMO. X-WIND 17 KTS.

In full view of the pilot when the oil cooler winterization kit is installed:

OIL COOLER WINTERIZATION PLATE TO BE
REMOVED WHEN AMBIENT TEMPERATURE
EXCEEDS 50°F.

**SECTION 2
LIMITATIONS**

**PIPER AIRCRAFT CORPORATION
PA-28-161, WARRIOR III**

In full view of the pilot:

UTILITY CATEGORY OPERATION ONLY

- (1) NO AFT PASSENGERS ALLOWED.
- (2) ACROBATIC MANEUVERS ARE LIMITED TO THE FOLLOWING:

	ENTRY SPEED
SPINS PROHIBITED	
STEEP TURNS	111 KIAS
LAZY EIGHTS	111 KIAS
CHANDELLES	111 KIAS

In full view of the pilot:

WARNING = TURN OFF STROBE LIGHTS WHEN IN CLOSE PROXIMITY TO GROUND OR DURING FLIGHT THROUGH CLOUD, FOG OR HAZE.

Adjacent to fuel filler caps (serial numbers 28-8316037 and up):

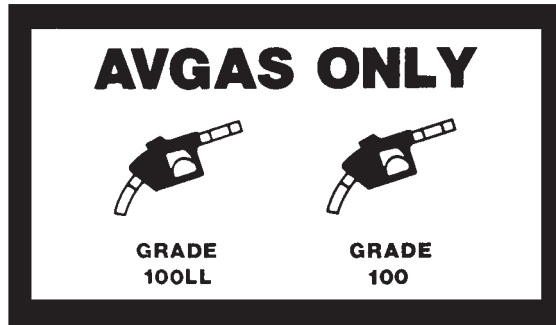

TABLE OF CONTENTS
SECTION 3
EMERGENCY PROCEDURES

Paragraph No.		Page No.
3.1	General	3-1
3.2	Airspeeds for Safe Operation	3-2
3.3	Emergency Procedures Checklist	3-3
	Engine Fire During Start	3-3
	Engine Power Loss During Takeoff	3-3
	Engine Power Loss In Flight	3-3
	Power Off Landing	3-4
	Fire In Flight.....	3-4
	Loss Of Oil Pressure	3-5
	Loss Of Fuel Pressure	3-5
	High Oil Temperature.....	3-5
	Electrical Failures.....	3-5
	Electrical Overload.....	3-5
	Spin Recovery	3-6
	Open Door	3-6
	Engine Roughness	3-7
	Carburetor Icing	3-7
3.5	Amplified Emergency Procedures (General)	3-9
3.7	Engine Fire During Start	3-9
3.9	Engine Power Loss During Takeoff	3-9
3.11	Engine Power Loss In Flight	3-10
3.13	Power Off Landing	3-11
3.15	Fire In Flight.....	3-11
3.17	Loss Of Oil Pressure	3-12
3.19	Loss Of Fuel Pressure	3-12
3.21	High Oil Temperature.....	3-13
3.23	Electrical Failures.....	3-13
3.24	Electrical Overload.....	3-14
3.25	Spin Recovery	3-15

TABLE OF CONTENTS

SECTION 3 (cont)

Paragraph No.		Page No.
3.27	Open Door	3-15
3.29	Carburetor Icing	3-15
3.31	Engine Roughness	3-16

**SECTION 3
EMERGENCY PROCEDURES**

3.1 GENERAL

The recommended procedures for coping with various types of emergencies and critical situations are provided by this section. All of required (FAA regulations) emergency procedures and those necessary for operation of the airplane as determined by the operating and design features of the airplane are presented.

Emergency procedures associated with those optional systems and equipment which require handbook supplements are provided in Section 9 (Supplements).

The first portion of this section consists of an abbreviated emergency check list which supplies an action sequence for critical situations with little emphasis on the operation of systems.

The remainder of the section is devoted to amplified emergency procedures containing additional information to provide the pilot with a more complete understanding of the procedures.

These procedures are suggested as a course of action for coping with the particular condition described, but are not a substitute for sound judgement and common sense. Pilots should familiarize themselves with the procedures given in this section and be prepared to take appropriate action should an emergency arise.

Most basic emergency procedures, such as power off landings, are a normal part of pilot training. Although these emergencies are discussed here, this information is not intended to replace such training, but only to provide a source of reference and review, and to provide information on procedures which are not the same for all aircraft. It is suggested that the pilot review standard emergency procedures periodically to remain proficient in them.

3.2 AIRSPEEDS FOR SAFE OPERATION

3.2a STALL SPEEDS

2440 lbs (0° Flaps).....50 KIAS
2440 lbs (Full Flaps).....44 KIAS

3.2b MANEUVERING SPEEDS

2440 lbs.....111 KIAS
1531 lbs.....88 KIAS

3.2c NEVER EXCEED SPEED

Never Exceed Speed.....160 KIAS

3.2c POWER OFF GLIDE SPEED

2325 lbs (0° Flaps).....73 KIAS

3.3 EMERGENCY PROCEDURES CHECKLIST

ENGINE FIRE DURING START

Startercrank engine
Mixtureidle cut-off
Throttleopen
Electric Fuel PumpOFF
Fuel SelectorOFF
Abandon if fire continues

POWER OFF LANDING

Locate suitable field.
Establish spiral pattern.
1000 ft. above field at downwind position for normal landing approach.
When field can easily be reached slow to 63 KIAS for shortest landing.
Touchdowns should normally be made at lowest possible airspeed with full flaps.

When committed to landing:

IgnitionOFF
Battery Master switchOFF
ALTR SwitchOFF
Fuel selectorOFF
Mixtureidle cut-off
Seat belts and harnessestight

FIRE IN FLIGHT

NOTE:

The possibility of an engine fire in flight is extremely remote.
The procedure given is general and Pilot judgment should be the determining factor for action in such an emergency.

Source of firecheck

Electrical fire (smoke in cabin):

Battery Master switchOFF
ALTR SwitchOFF
Ventsopen
Cabin heatOFF

Land as soon as practical.

Engine fire:

Fuel selectorOFF
ThrottleCLOSED
Mixtureidle cut-off
Electric fuel pumpcheck OFF
HeaterOFF
DefrosterOFF

Proceed with POWER OFF LANDING procedure.

LOSS OF OIL PRESSURE

Land as soon as possible and investigate cause.
Prepare for power off landing.

LOSS OF FUEL PRESSURE

Electric fuel pumpON
Fuel selectorcheck on tank
containing fuel

HIGH OIL TEMPERATURE

Land at nearest airport and investigate the problem.
Prepare for power off landing.

ELECTRICAL FAILURES

NOTE:

Anytime the bus voltage is below 25 Vdc, the Low
Bus Voltage Annunciator will be illuminated.

ALT annunciator light illuminated:

AmmeterCheck to verify inop. alt.

If ammeter shows zero:

ALT switchOFF

Reduce electrical loads to minimum:

ALT circuit breakerCheck and reset
as required

ALT switchON

If power not restored:

ALT switchOFF

If alternator output cannot be restored, reduce electrical loads and land as soon as practical. Anticipate complete electrical failure. Duration of battery power will be dependent on electrical load and battery condition prior to failure.

**SECTION 3
EMERGENCY PROCEDURES**

**PIPER AIRCRAFT CORPORATION
PA-28-161, WARRIOR III**

ELECTRICAL OVERLOAD (Alternator over 20 amps above known electrical load)

ALT switchON
Battery Master switchOFF
If alternator loads are reduced:
Electrical loadReduce to Minimum

Land as soon as practical.

NOTE

Due to increased system voltage and radio frequency noise, operation with ALT switch ON and BATT switch OFF should be made only when required by an electrical system failure.

If alternator loads are not reduced:

ALT switchOFF
BATT switchAs required

Land as soon as possible. Anticipate complete electrical failure.

SPIN RECOVERY

Rudder.....full opposite to
direction of rotation
Control wheel.....full forward while
neutralizing ailerons
Throttle.....idle
Rudder.....neutral (when rotation stops)
Control wheelas required to smoothly
regain level flight attitude

OPEN DOOR

If both upper and lower latches are open, the door will trail slightly open and airspeeds will be reduced slightly.

To close the door in flight:

Slow airplane to 89 KIAS

Cabin ventsclose

Storm windowopen

If upper latch is openlatch

If side latch is openpull on arm rest while
moving latch handle to
latched position.

If both latches are openlatch side latch
then top latch.

ENGINE ROUGHNESS

Carburetor HeatON

If roughness continues after one min:

Carburetor Heat.....OFF

Mixture.....adjust for max.
smoothness

Electric Fuel PumpON

Fuel Selector.....switch tanks

Engine Gaugescheck

Magneto SwitchL then R
then BOTH

If operation is satisfactory on either magneto, continue on that magneto at reduced power and full RICH mixture to first airport.

Prepare for power off landing.

CARBURETOR ICING

Carburetor HeatON

Mixture.....adjust for max.
smoothness

THIS PAGE INTENTIONALLY LEFT BLANK

3.5 AMPLIFIED EMERGENCY PROCEDURES (GENERAL)

The following paragraphs are presented to supply additional information for the purpose of providing the pilot with a more complete understanding of the recommended course of action and probable cause of an emergency situation.

3.7 ENGINE FIRE DURING START

Engine fires during start are usually the result of overpriming. The first attempt to extinguish the fire is to try to start the engine and draw the excess fuel back into the induction system.

If a fire is present before the engine has started, move the mixture control to idle cut-off, open the throttle and crank the engine. This is an attempt to draw the fire back into the engine.

If the engine has started, continue operating to try to pull the fire into the engine.

In either case (above), if fire continues more than a few seconds, the fire should be extinguished by the best available external means.

The fuel selector valves should be OFF and the mixture at idle cut-off if an external fire extinguishing method is to be used.

3.9 ENGINE POWER LOSS DURING TAKEOFF

The proper action to be taken if loss of power occurs during takeoff will depend on the circumstances of the particular situation.

If sufficient runway remains to complete a normal landing, land straight ahead.

If insufficient runway remains, maintain a safe airspeed and make only a shallow turn if necessary to avoid obstructions. Use of flaps depends on the circumstances. Normally, flaps should be fully extended for touchdown.

If sufficient altitude has been gained to attempt a restart, maintain a safe airspeed and switch the fuel selector to another tank containing fuel. Check the electric fuel pump to ensure that it is ON and that the mixture is RICH. The carburetor heat should be ON.

If engine failure was caused by fuel exhaustion, power will not be regained after switching fuel tanks until the empty fuel lines are filled. This may require up to ten seconds.

If power is not regained, proceed with the Power Off Landing procedure (refer to the emergency check list and paragraph 3.13).

3.11 ENGINE POWER LOSS IN FLIGHT

Complete engine power loss is usually caused by fuel flow interruption, and power will be restored shortly after fuel flow is restored. If power loss occurs at a low altitude, the first step is to prepare for an emergency landing (refer to paragraph 3.13). An airspeed of at least 73 KIAS should be maintained.

If altitude permits, switch the fuel selector to another tank containing fuel and turn the electric fuel pump ON. Move the mixture control to RICH and the carburetor heat to ON. Check the engine gauges for an indication of the cause of the power loss. If no fuel pressure is indicated, check the tank selector position to be sure it is on a tank containing fuel.

When power is restored move the carburetor heat to the OFF position and turn OFF the electric fuel pump.

If the preceding steps do not restore power, prepare for an emergency landing.

If time permits, turn the magneto switch to L then to R then back to BOTH. Move the throttle and mixture control levers to different settings. This may restore power if the problem is too rich or too too lean a mixture or if there is a partial fuel system restriction. Try other fuel tanks. Water in the fuel could take some time to be used up, and allowing the engine to windmill may restore power. If power loss is due to water, fuel pressure indications will be normal.

If engine failure was caused by fuel exhaustion, power will not be restored after switching fuel tanks until the empty fuel lines are filled. This may required up to ten seconds.

If power is not regained, proceed with the Power Off Landing procedure (refer to the emergency checklist and paragraph 3.13).

3.13 POWER OFF LANDING

If loss of power occurs at altitude, trim the aircraft for best gliding angle (73 KIAS) and look for a suitable field. If measures taken to restore power are not effective, and if time permits, check your charts for airports in the immediate vicinity; it may be possible to land at one if you have sufficient altitude. If possible, notify the FAA by radio of your difficulty and intentions. If another pilot or passenger is aboard, let him help.

When you have located a suitable field, establish a spiral pattern around this field. Try to be at 1000 feet above the field at the downwind position to make a normal landing approach. When the field can easily be reached, slow to 63 KIAS for the shortest landing. Excess altitude may be lost by widening your pattern, using flaps or slipping, or a combination of these.

Touchdown should normally be made at the lowest possible airspeed.

When committed to a landing, lower the flaps as desired, close the throttle, move the mixture to idle cut-off, and shut OFF the magnetos. Turn the battery master and alternator switches OFF. Move the fuel selector valve to OFF. The seat belts and shoulder harness should be tightened.

3.15 FIRE IN FLIGHT

The presence of fire is noted through smoke, smell and heat in the cabin. It is essential that the source of the fire be promptly identified through instrument readings, characteristics of the smoke, or other indications since the action to be taken differs somewhat in each case.

Check for the source of the fire first.

If an electrical fire is indicated (smoke in the cabin), the battery master switch should be turned OFF. The cabin vents should be opened and the cabin heat turned OFF. A landing should be made as soon as possible.

If an engine fire is present, switch the fuel selector to OFF and close the throttle. The mixture should be at idle cut-off. Turn the electric fuel pump OFF. In all cases, the heater and defroster should be OFF. If radio communication is not required, select battery master and alternator switches OFF. Proceed with power off landing procedure.

NOTE::

The possibility of an engine fire in flight is extremely remote. The procedure given is general and pilot judgement should be the determining factor for action in such an emergency.

3.17 LOSS OF OIL PRESSURE

Loss of oil pressure may be either partial or complete. A partial loss of oil pressure usually indicates a malfunction in the oil pressure regulating system, and a landing should be made as soon as possible to investigate the cause and prevent engine damage.

A complete loss of oil pressure indication may signify oil exhaustion or may be the result of a faulty gauge. In either case, proceed toward the nearest airport, and be prepared for a forced landing. If the problem is not a pressure gauge malfunction, the engine may stop suddenly. Maintain altitude until such time as a dead stick landing can be accomplished. Don't change power settings unnecessarily, as this may hasten complete power loss.

Depending on the circumstances, it may be advisable to make an off airport landing while power is still available, particularly if other indications of actual oil pressure loss, such as sudden increases in temperatures, or oil smoke, are apparent, and an airport is not close.

If engine stoppage occurs, proceed with a Power Off Landing.

3.19 LOSS OF FUEL PRESSURE

The most probable cause of loss of fuel pressure is either fuel depletion in the fuel tank selected or failure of the engine driven fuel pump. If loss of fuel pressure occurs, turn ON the electric fuel pump and check that the fuel selector is on a tank containing usable fuel.

If loss of fuel pressure is due to failure of the engine driven fuel pump the electric fuel pump will supply sufficient fuel pressure.

3.19 LOSS OF FUEL PRESSURE (CONT'D)

After fuel pressure and power are regained, turn the electric fuel pump OFF. If fuel pressure starts to drop, turn the electric fuel pump ON and land at the nearest suitable airport as soon as possible and have the cause investigated.

CAUTION

If normal engine operation and fuel pressure is not immediately re-established, the electric fuel pump should be turned off. The lack of fuel pressure indication could indicate a leak in the fuel system, or fuel exhaustion.

3.21 HIGH OIL TEMPERATURE

An abnormally high oil temperature indication may be caused by a low oil level, an obstruction in the oil cooler, damaged or improper baffle seals, a defective gauge, or other causes. Land as soon as practical at an appropriate airport and have the cause investigated.

A steady, rapid rise in oil temperature is a sign of trouble. Land at the nearest airport and let a mechanic investigate the problem. Watch the oil pressure gauge for an accompanying loss of pressure.

3.23 ELECTRICAL FAILURES

NOTE:

Anytime the bus voltage is below 25 Vdc, the Low Bus Voltage Annunciator will be illuminated.

Loss of alternator output is detected through zero reading on the ammeter and alternator inop annunciator. Before executing the following procedure, ensure that the reading is zero, and not merely low, by actuating an electrically powered device, such as the landing light. If no increase in the ammeter reading is noted, alternator failure can be assumed.

The electrical load should be reduced as much as possible. Check for an open alternator field circuit breaker.

Next attempt to reset the overvoltage relay by moving the ALTR switch to OFF for one second and then to ON. If the trouble was caused by a momentary overvoltage condition (30.5 volts and up) this procedure should return the ammeter to a normal reading.

3.23 ELECTRICAL FAILURES (CONT'D)

NOTE:

Low Bus Voltage Annunciator and Alternator
Inop. Annunciator will be illuminated.

If the ammeter continues to indicate ZERO output, or if the alternator will not remain reset, turn off the ALTR switch, maintain minimum electrical load and land as soon as practical. Anticipate complete electrical failure. Duration of battery power will be dependent on electrical load and battery condition prior to failure.

3.24 ELECTRICAL OVERLOAD (Alternator over 20 amps above known electrical load)

If abnormally high alternator output is observed (more than 20 amps above known electrical load for the operating conditions), it may be caused by a low battery, a battery fault or other abnormal electrical load. If the cause is a low battery, the indication should begin to decrease toward normal within 5 minutes. If the overload condition persists, attempt to reduce the load by turning off non-essential equipment.

Turn the BATT switch OFF and the ammeter should decrease. Turn the BATT switch ON and continue to monitor the ammeter. If the alternator output does not decrease within 5 minutes, turn the BATT switch OFF and land as soon as possible. All electrical loads are being supplied by the alternator.

NOTE

Due to higher voltage and radio frequency noise, operation with the ALT switch ON and the BATT switch OFF should be made only when required by an electrical failure.

3.25 SPIN RECOVERY

Intentional spins are prohibited in this airplane. If a spin is inadvertently entered, immediately apply full rudder opposite to the direction of rotation. Move the control wheel full forward while neutralizing the ailerons. Move the throttle to IDLE. When the rotation stops, neutralize the rudder and ease back on the control wheel as required to smoothly regain a level flight attitude.

3.27 OPEN DOOR

The cabin door on the Cherokee is double latched, so the chance of it springing open in flight at both the top and side are remote. However, should you forget the upper latch, or not fully engage the side latch, the door may spring partially open. This will usually happen at takeoff or soon afterward. A partially open door will not affect normal flight characteristics, and a normal landing can be made with the door open.

If both upper and side latches are open, the door will trail slightly open, and airspeed will be reduced slightly.

To close the door in flight, slow the airplane to 89 KIAS, close the cabin vents and open the storm window. If the top latch is open, latch it. If the side latch is open, pull on the arm rest while moving the latch handle to the latched position. If both latches are open, close the side latch then the top latch.

3.29 CARBURETOR ICING

Under certain moist atmospheric conditions at temperatures of -5°C to 20°C , it is possible for ice to form in the induction system, even in summer weather. This is due to the high air velocity through the carburetor venturi and absorption of heat from this air by vaporization of the fuel.

To avoid this, carburetor preheat is provided to replace the heat lost by vaporization. Carburetor heat should be full on when carburetor ice is encountered. Adjust mixture for maximum smoothness.

3.31 ENGINE ROUGHNESS

Engine roughness is usually due to carburetor icing which is indicated by a drop in RPM, and may be accompanied by a slight loss of airspeed or altitude. If too much ice is allowed to accumulate, restoration of full power may not be possible; therefore, prompt action is required.

Turn carburetor heat on (see Note). RPM will decrease slightly and roughness will increase. Wait for a decrease in engine roughness or an increase in RPM, indicating ice removal. If there is no change in approximately one minute, return the carburetor heat to OFF.

If the engine is still rough, adjust the mixture for maximum smoothness. The engine will run rough if the mixture is too rich or too lean. The electric fuel pump should be switched to ON and the fuel selector switched to the other tank to see if fuel contamination is the problem. Check the engine gauges for abnormal readings. If any gauge readings are abnormal, proceed accordingly. Move the magneto switch to L then to R, then back to BOTH. If operation is satisfactory on either magneto, proceed on that magneto, at reduced power, with mixture full RICH, to a landing at the first available airport.

If roughness persists, prepare for a precautionary landing at pilot's discretion.

NOTE

Partial carburetor heat may be worse than no heat at all, since it may melt part of the ice which will refreeze in the intake system. Therefore when using carburetor heat always use full heat; and, when ice is removed, return the control to the full cold position.

TABLE OF CONTENTS

SECTION 4

NORMAL PROCEDURES

Paragraph No.		Page No.
4.1	General	4-1
4.3	Airspeeds For Safe Operations.....	4-2
4.5	Normal Procedures Check List	4-3
	Preparation	4-3
	Preflight Check.....	4-4
	Before Starting Engine	4-6
	Starting Engine When Cold.....	4-6
	Starting Engine When Hot	4-6
	Starting Engine When Flooded	4-7
	Starting With External Power Source.....	4-7
	Warm-Up	4-7
	Taxiing	4-7
	Ground Check	4-8
	Before Takeoff.....	4-8
	Takeoff.....	4-9
	Climb	4-10
	Cruising	4-10
	Descent	4-10
	Approach And Landing	4-11
	Stopping Engine	4-11
	Parking.....	4-11
4.7	Amplified Normal Procedures (General)	4-12
4.9	Preflight Check.....	4-12
4.11	Before Starting Engine	4-15
4.13	Starting Engine	4-15
4.15	Warm-Up	4-17
4.17	Taxiing	4-18
4.19	Ground Check	4-18

TABLE OF CONTENTS

SECTION 4 (cont)

Paragraph No.		Page No.
4.21	Before Takeoff.....	4-19
4.23	Takeoff.....	4-20
4.25	Climb.....	4-21
4.27	Cruising.....	4-21
4.29	Descent.....	4-22
4.31	Approach And Landing.....	4-23
4.33	Stopping Engine.....	4-24
4.35	Parking.....	4-24
4.37	Stalls.....	4-25
4.39	Turbulent Air Operation.....	4-25
4.41	Weight And Balance.....	4-25
4.43	Noise Levels.....	4-26

**SECTION 4
NORMAL PROCEDURES**

4.1 GENERAL

This section describes the recommended procedures for the conduct of normal operations for the WARRIOR III. All of the required (FAA regulations) procedures and those necessary for operation of the airplane as determined by the operating and design features of the airplane are presented.

Normal procedures associated with those optional systems and equipment which require handbook supplements are provided by Section 9 (Supplements).

These procedures are provided to present a source of reference and review and to supply information on procedures which are not the same for all aircraft. Pilots should familiarize themselves with the procedures given in this section in order to become proficient in the normal operations of the airplane.

The first portion of this section consists of a short form checklist which supplies an action sequence for normal operations with little emphasis on the operation of the systems.

The remainder of the section is devoted to amplified normal procedures which provide detailed information and explanations of the procedures and how to perform them. This portion of the section is not intended for use as an in-flight reference due to the lengthy explanations. The short form checklist should be used for this purpose.

4.3 AIRSPEEDS FOR SAFE OPERATIONS

The following airspeeds are those which are significant to the operation of the airplane. These figures are for standard airplanes flown at gross weight under standard conditions at sea level.

Performance for a specific airplane may vary from published figures depending upon the equipment installed; the condition of the engine, airplane and equipment; atmospheric conditions and piloting technique.

(a) Best Rate of Climb Speed	79 KIAS
(b) Best Angle of Climb Speed	63 KIAS
(c) Turbulent Air Operating Speed (See Subsection 2.3)	111 KIAS
(d) Maximum Flap Speed	103 KIAS
(e) Landing Final Approach Speed (Flaps 40°)	63 KIAS
(f) Maximum Demonstrated Crosswind Velocity	17 KTS

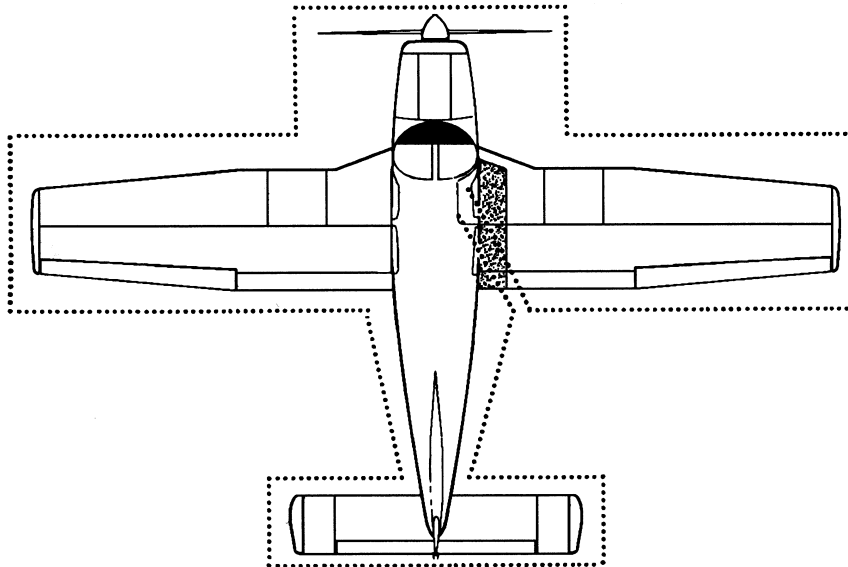

WALK-AROUND
Figure 4-1

4.5 NORMAL PROCEDURES CHECKLIST

PREPARATION

Airplane status.....airworthy, papers on board
Weathersuitable
Baggageweighed, stowed, tied
Weight and C.G.....within limits
Navigationplanned
Charts and navigation equipment.....on board
Performance and range.....computed and safe

PREFLIGHT CHECK

COCKPIT

Control wheelrelease belts
AvionicsOFF
Parking brakeSet
Electric switchesOFF
Magneto switch.....OFF
Mixtureidle cut-off
Master switchON
Fuel quantity gaugescheck
Annunciator panel.....check
Master switch.....OFF
Flight controlscheck
Flaps.....check
Trimcheck, set neutral
Pitot drainDRAIN, close
Static drainDRAIN, close
Windowscheck, clean
Tow barstow
Baggage.....secure
Baggage doorclose, secure

RIGHT WING

Wingfree of ice, snow, frost
Control surfacescheck for interference -
free of ice, snow, frost
Hingescheck for interference
Static wickscheck
Wing tip and lights.....check
Fuel tank.....check supply
visually - secure caps
Fuel tank sumpdrain, check for water,
sediment and proper fuel
Fuel ventclear
Tie down and chock.....remove
Main gear strut.....proper
inflation (4.50 in.)
Tirecheck
Brake block and discscheck
Fresh air inlet.....clear

NOSE SECTION

Fuel and oilcheck for leaks
Cowling.....secure
Windshield.....clean
Propeller and spinnercheck
Air inlets.....clear
Alternator beltcheck tension
Landing light.....check
Nose chock.....remove
Nose gear strut.....proper
inflation (3.25 in.)
Nose wheel tirecheck
Oilcheck level
Dipstick.....properly seated
Fuel strainer.....drain, check for water,
sediment and proper fuel

LEFT WING

Wingfree of ice, snow, frost
Fresh air inlet.....clear
Main gear strut.....proper
inflation (4.50 in.)
Tirecheck
Brake block and discscheck
Fuel tankscheck supply
visually - secure caps
Fuel tank sumps.....drain, check for water,
sediment and proper fuel
Fuel ventsopen
Tie down and chock.....remove
Pitot head.....remove cover -
holes clear
Wing tip and lights.....check
Control surfacescheck for interference -
free of ice, snow, frost
Hingescheck for interference
Static wickscheck

FUSELAGE

Antennascheck
EmpennageFree of ice, snow, frost

**SECTION 4
NORMAL PROCEDURES**

**PIPER AIRCRAFT CORPORATION
PA-28-161, WARRIOR III**

Fresh air inlet.....clear
Stabilator and trim tab.....check for interference
Tie down.....remove
Master switchON
Cockpit lightingcheck
Nav and strobe lightscheck
Stall warning.....check
Pitot heatcheck
All switchesOFF
Passengers.....board
Cabin door.....close and secure
Seat belts and harnessesfasten - check
interia reel

BEFORE STARTING ENGINE

Brakesset
Carburetor Heatfull OFF
Fuel Selectordesired tank
RadiosOFF

STARTING ENGINE WHEN COLD

Throttle1/4" open
Master switchON
Electric fuel pumpON
Mixture.....full RICH
Starter.....engage
Throttleadjust
Oil Pressure.....check
If engine does not start within 10 sec., prime and repeat starting procedure.

STARTING ENGINE WHEN HOT

Throttle1/2" open
Master Switch.....ON
Electric fuel pumpON
Mixture.....full RICH
Starter.....engage

Throttleadjust
Oil pressurecheck

STARTING ENGINE WHEN FLOODED

Throttleopen full
Master switchON
Electric fuel pump.....OFF
Mixtureidle cut-off
Starter.....engage
Mixture.....advance
Throttleretard
Oil pressurecheck

STARTING ENGINE WITH EXTERNAL POWER SOURCE

Master switch.....OFF
All electrical equipment.....OFF
Terminalsconnect
External power pluginsert in
fuselage
Proceed with normal start
Throttlelowest possible
RPM
External power plugdisconnect from
fuselage
Master switch.....ON - check ammeter
Oil Pressure.....check

WARM-UP

Throttle800 to 1200 RPM

TAXIING

Chocksremoved
Taxi areaclear
Throttleapply slowly
Brakescheck
Steeringcheck

GROUND CHECK

Throttle2000 RPM
Magnetosmax. drop 175 RPM
 -max. diff. 50 RPM
Vacuum4.8" to 5.2" Hg
Oil tempcheck
Oil pressurecheck
Annunciator panel.....press-to-test
Carburetor Heat.....check
 (Observe approx. 75 RPM drop)

Engine is warm for takeoff when throttle can be opened without engine faltering.

Electric fuel pump.....OFF
Fuel pressurecheck
ThrottleRETARD

BEFORE TAKEOFF

Master switchON
Flight instrumentscheck
Fuel selectorproper tank
Electric fuel pumpON
Engine gaugescheck
Carburetor heatOFF
Seat backserect
Mixtureset
Belts/harness.....fastened/check
Empty seatsseat belts
 snugly fastened
Flaps.....set
Trim tab.....set
Controls.....free
Door.....latch

TAKEOFF

NORMAL

Flaps.....set
Trimset
Accelerate to 45 to 55 KIAS
Control wheel.....back pressure to
rotate to climb attitude

0° FLAPS TAKEOFF PERFORMANCE

Flaps.....UP
Accelerate to 40-52 KIAS (depending on weight)
Control Wheel.....back pressure to
rotate to climb attitude
Accelerate to and maintain 44 to 57 KIAS (depending on weight) until
obstacle clearance is achieved and climb out at 79 KIAS.

25° FLAPS TAKEOFF PERFORMANCE

Flaps.....25° (second notch)
Accelerate to 40-52 KIAS (depending on weight)
Control Wheel.....back pressure to
rotate to climb attitude
Accelerate to and maintain 44 to 57 KIAS (depending on weight) until
obstacle clearance is achieved and climb out at 79 KIAS.
Flapsretract slowly

SOFT FIELD, OBSTACLE CLEARANCE

Flaps.....25° (second notch)
Accelerate and lift off nose gear as soon as possible. Lift off at lowest possible
airspeed. Accelerate just above ground to 52 KIAS to climb past obstacle
height. Continue climbing while accelerating to best rate of climb speed, 79
KIAS.
Flapsretract slowly

**SECTION 4
NORMAL PROCEDURES**

**PIPER AIRCRAFT CORPORATION
PA-28-161, WARRIOR III**

SOFT FIELD, NO OBSTACLE

Flaps25° (second notch)
Accelerate and lift off nose gear as soon as possible. Lift off at lowest possible airspeed. Accelerate just above ground to best rate of climb speed, 79 KIAS.
Flapsretract slowly

CLIMB

Best rate (flaps up)79 KIAS
Best angle (flaps up)63 KIAS
En route87 KIAS
Electric fuel pumpOFF at
desired altitude

CRUISING

Reference performance charts and Avco-Lycoming Operators Manual.
Normal max power75%
Powerset per power table
Mixtureadjust

DESCENT

NORMAL

Throttle2500 rpm
Airspeed126 KIAS
Mixturerich
Carburetor heatON if required

POWER OFF

Carburetor heatON if required
Throttleclose
Airspeedas required
Mixtureas required
Powerverify with throttle every 30 seconds

APPROACH AND LANDING

Fuel selectorproper tank
Seat backserect
Belts/harnessfasten/check
Electric fuel pumpON
Mixtureset
Flapsset - 103 KIAS max
Air conditionerOFF
Trim to 70 KIAS
Final approach speed (flaps 40°)63 KIAS

STOPPING ENGINE

Flapsretract
Electric fuel pumpOFF
Air ConditionerOFF
RadiosOFF
Throttlefull aft
Mixtureidle cut-off
MagnetosOFF
Master switchOFF

PARKING

Parking brakeset
Control wheelsecure with belts
Flapsfull up
Wheel chocksin place
Tie downssecure

4.7 AMPLIFIED NORMAL PROCEDURES (GENERAL)

The following paragraphs are provided to supply detailed information and explanations of the normal procedures necessary for the safe operation of the airplane.

4.9 PREFLIGHT CHECK

PREPARATION

The airplane should be given a thorough preflight and walk-around check. The preflight should include a check of the airplane's required papers, operational status, computation of weight and C.G. limits, takeoff and landing distances, and in-flight performance. A weather briefing should be obtained for the intended flight path, and any other factors relating to a safe flight should be checked before takeoff.

CAUTION

The flap position should be noted before boarding the airplane. The flaps must be placed in the UP position before they will lock and support weight on the step.

COCKPIT

Upon entering the cockpit, release the seat belts securing the control wheel, turn OFF all avionics equipment, and set the parking brake. Insure that all electrical switches and the magneto switch are OFF and that the mixture is in idle cut-off. Turn ON the master switch, check the fuel quantity gauges for adequate supply and check that the annunciator panel illuminates. Turn OFF the master switch. Check the primary flight controls and flaps for proper operation and set the trim to neutral. Open the pitot and static drains to remove any moisture that has accumulated in the lines. Check the windows for cleanliness. Properly stow the tow bar and baggage and secure. Close and secure the baggage door.

RIGHT WING

Begin the walk-around at the trailing edge of the right wing by checking that the wing surface and control surfaces are clear of ice, frost, snow or other extraneous substances. Check the flap, aileron and hinges for damage and operational interference. Static wicks should be firmly attached and in good condition. Check the wing tip and lights for damage.

Open the fuel cap and visually check the fuel color and the quantity should match the indication that was on the fuel quantity gauge, replace cap securely. The fuel tank vent should be clear of obstructions.

Drain the fuel tank through the quick drain located at the lower inboard rear corner of the tank, making sure that enough fuel has been drained to insure that all water and sediment is removed. The fuel system should be drained daily prior to the first flight and after each refueling and checked for proper fuel.

CAUTION

When draining any amount of fuel, care should be taken to insure that no fire hazard exists before starting engine.

Remove the tie down and chock.

Next, a check of the landing gear. Check the gear strut for proper inflation; there should be $4.50 \pm .25$ inches of strut exposure under a normal static load. Check the tire for cuts, wear, and proper inflation. Make a visual check of the brake block and disc.

Check that the fresh air inlet is clear of foreign matter.

NOSE SECTION

Check the general condition of the nose section, look for oil or fluid leakage and that the cowling is secure. Check the windshield and clean if necessary. The propeller and spinner should be checked for detrimental nicks, cracks, or other defects. The air inlets should be clear of obstructions and check the alternator belt for proper tension. The landing light should be clean and intact.

**SECTION 4
NORMAL PROCEDURES**

**PIPER AIRCRAFT CORPORATION
PA-28-161, WARRIOR III**

Remove the chock and check the nose gear strut for proper inflation, there should be $3.25 \pm .25$ inches of strut exposure under a normal static load. Check the tire for cuts, wear, and proper inflation. Check the engine baffle seals. Check the oil level, make sure that the dipstick has been properly seated.

Open the fuel strainer located on the left side of the firewall long enough to remove any accumulation of water and sediment and check for proper fuel.

LEFT WING

The wing surface should be clear of ice, frost, snow, or other extraneous substances. Check that the fresh air inlet is clear of foreign matter and remove the chock. Check the main gear strut for proper inflation, there should be $4.50 \pm .25$ inches of strut exposure under a normal static load. Check the tire and the brake block and disc.

Open the fuel cap and visually check the fuel color. The quantity should match the indication on the fuel quantity gauge. Replace cap securely. The fuel tank vent should be clear of obstructions. Drain enough fuel to insure that all water and sediment has been removed and check for proper fuel.

Remove tie down and chock. Remove the cover from the pitot/static head on the underside of the wing. Make sure the holes are open and clear of obstructions. Check the wing tip and lights for damage. Check the aileron, flap, and hinges for damage and operational interference and that the static wicks are firmly attached and in good condition.

FUSELAGE

Check the condition and security of the antennas. The empennage should be clear of ice, frost, snow, or other extraneous substances, and the fresh air inlet on the side of fuselage should be clear of foreign matter. Check the stabilator and trim tab for damage and operational interference. The trim tab should move in the same direction as the stabilator. Remove the tie down.

Upon returning to the cockpit, an operational check of the interior lights, exterior lights, stall warning system, and pitot heat should now be made. Turn the battery master switch and other appropriate switches ON. Check the panel lighting and the overhead flood light. Visually confirm that exterior lights are operational. Lift the stall detector on the leading edge of the left

wing and determine that the warning horn is activated. With the pitot heat switch ON, the pitot head will be hot to the touch. After these checks are complete, the master switch and all electrical switches should be turned OFF.

Board the passengers and close and secure the cabin door. Fasten the seat belts and shoulder harnesses. Pull test the locking restraint feature of the shoulder harness inertia reel. Fasten seat belts on empty seats.

4.11 BEFORE STARTING ENGINE

Before starting the engine the brakes should be set ON and the carburetor heat lever moved to the full OFF position. The fuel selector should then be moved to the desired tank. Check to make sure that all the radios are OFF.

4.13 STARTING ENGINE

(a) Starting Engine When Cold

Open the throttle lever approximately 1/4 inch. Turn ON the master switch and the electric fuel pump.

Move the mixture control to full RICH and engage the starter by rotating the magneto switch clockwise. When the engine fires, release the magneto switch, and move the throttle to the desired setting.

If the engine does not fire within five to ten seconds, disengage the starter, prime the engine and repeat the starting procedure (priming is accomplished by lifting the switch guard and depressing the momentary electric prime button for the desired time.)

(b) Starting Engine When Hot

Open the throttle approximately 1/2 inch. Turn ON the master switch and the electric fuel pump. Move the mixture control lever to full RICH and engage the starter by rotating the magneto switch clockwise. When the engine fires, release the magneto switch and move the throttle to the desired setting.

(c) Starting Engine When Flooded

The throttle lever should be full OPEN. Turn ON the master switch and turn OFF the electric fuel pump. Move the mixture control lever to idle cut-off and engage the starter by rotating the magneto switch clockwise. When the engine fires, release the magneto switch, advance the mixture and retard the throttle.

(d) Starting Engine With External Power Source

An External Power receptacle allows the operator to use an external battery to crank the engine without having to gain access to the airplane's battery.

Turn the master switch OFF and turn all electrical equipment OFF. Insert the plug of a 28 volt DC aux power jumper cable into the socket located on the fuselage. Note that when the plug is inserted, the electrical system is ON. Proceed with the normal starting technique.

After the engine has started reduce power to the lowest possible RPM, to reduce sparking, and disconnect the jumper cable from the aircraft. Turn the master switch ON and check the alternator ammeter for an indication of output. **DO NOT ATTEMPT FLIGHT IF THERE IS NO INDICATION OF ALTERNATOR OUTPUT.**

NOTE

For all normal operations using the Aux Power jumper cables, the master switch should be OFF, but it is possible to use the ship's battery in parallel by turning the master switch ON. This will give longer cranking capabilities, but will not increase the amperage.

CAUTION

Care should be exercised, because, if the ship's battery has been depleted, the external power supply can be reduced to the level of the ship's battery. This can be tested by turning the master switch ON momentarily while the starter is engaged. If cranking speed increases, the ship's battery is at a higher level than the external power supply.

When the engine is firing evenly, advance the throttle to 800 rpm. If oil pressure is not indicated within thirty seconds, stop the engine and determine the trouble. In cold weather it will take a few seconds longer to get an oil pressure indication. If the engine has failed to start, refer to the Lycoming Operating Handbook, Engine Troubles and Their Remedies.

NOTE:

Starter manufacturer recommends starter cranking periods be limited to 10 seconds with a 20 second rest period between cranking attempts. Maximum of 6 start periods allowed. If start is not achieved on sixth attempt allow starter to cool for 30 minutes before attempting additional starts.

4.15 WARM-UP

Warm-up the engine at 800 to 1200 RPM for not more than two minutes in warm weather and four minutes in cold. Avoid prolonged idling at low RPM, as this practice may result in fouled spark plugs.

Takeoff may be made as soon as the ground check is completed, provided that the throttle may be opened fully without backfiring or skipping, and without a reduction in engine oil pressure.

Do not operate the engine at high rpm when running up or taxiing over ground containing loose stones, gravel or any loose material that may cause damage to the propeller blades.

4.17 TAXIING

Before attempting to taxi the airplane, ground personnel should be instructed and approved by a qualified person authorized by the owner. Ascertain that the propeller back blast and taxi areas are clear.

Power should be applied slowly to start the taxi roll. Taxi a few feet forward and apply the brakes to determine their effectiveness. While taxiing, make slight turns to ascertain the effectiveness of the steering.

Observe wing clearances when taxiing near buildings or other stationary objects. If possible, station an observer outside the airplane.

Avoid holes and ruts when taxiing over uneven ground.

Do not operate the engine at high rpm when running up or taxiing over ground containing loose stones, gravel or any loose material that may cause damage to the propeller blades.

4.19 GROUND CHECK

The magnetos should be checked at 2000 RPM. Drop off on either magneto should not exceed 175 RPM and the difference between the magnetos should not exceed 50 RPM. Operation on one magneto should not exceed 10 seconds.

Check the vacuum gauge; the indicator should read 4.8" to 5.2" Hg at 2000 RPM.

Check the annunciator panel lights with the press-to-test button.

Carburetor heat should also be checked prior to takeoff to be sure the control is operating properly and to clean any ice which may have formed during taxiing. Avoid prolonged ground operation with carburetor heat ON as the air is unfiltered.

The electric fuel pump should be turned OFF after starting or during warm-up to make sure that the engine driven pump is operating. Check both oil temperature and oil pressure. The temperature may be low for some time if the engine is being run for the first time of the day. The engine is warm enough for takeoff when the throttle can be opened without the engine faltering.

4.21 BEFORE TAKEOFF

All aspects of each particular takeoff should be considered prior to executing the takeoff procedure.

Insure that the master switch is ON. Check and set all of the flight instruments as required. Check the fuel selector to make sure it is on the proper tank (fullest). Turn ON the electric fuel pump to prevent loss of power should the engine driven pump fail during takeoff, and check the engine gauges. The carburetor heat should be in the OFF position.

All seat backs should be erect and the seat belts and shoulder harness should be fastened. Pull test the locking restraint feature of the shoulder harness inertia reel. Fasten the seat belts snugly around the empty seats.

The mixture should be set.

NOTE

The mixture should be set FULL RICH, but a minimum amount of leaning is permitted for smooth engine operation when taking off at high elevation.

Exercise and set the flaps and trim tab. Insure proper flight control movement and response. The door should be properly secured and latched.

4.23 TAKEOFF (See charts in Section 5)

The normal takeoff technique is conventional. The trim should be set slightly aft of neutral, with the exact setting determined by the loading of the airplane. Allow the airplane to accelerate to 45 to 55 KIAS depending on the weight of the aircraft and ease back on the control wheel to rotate to climb attitude. Premature raising of the nose or raising it to an excessive angle will result in a delayed takeoff. After takeoff, let the airplane accelerate to the desired climb speed by lowering the nose slightly.

Takeoffs are normally made with flaps up; however, for short field takeoffs and for takeoffs under difficult conditions, such as deep grass or a soft surface, total distances can be reduced appreciably by lowering the flaps to 25° and rotating at lower airspeed.

A short field takeoff is accomplished without flaps by applying full power before brake release; lift off at 40-52 KIAS (depending on weight) and accelerate to and maintain 44-57 KIAS (depending on weight) past obstacle and climb out at 79 KIAS.

A short field takeoff with an obstacle clearance is accomplished by first lowering the flaps to 25°. Apply full power before brake release and accelerate to 40-52 KIAS (depending on weight) and rotate. Accelerate to and maintain 44-57 KIAS (depending on weight) until obstacle clearance is attained. After the obstacle has been cleared, accelerate to 79 KIAS and then slowly retract the flaps.

Takeoff from a soft field with an obstacle clearance requires the use of 25° flaps. Accelerate the airplane and lift the nose gear off as soon as possible and lift off at the lowest possible airspeed. Accelerate just above the ground to 52 KIAS to climb past obstacle clearance height. Continue climbing while accelerating to the best rate of climb speed, 79 KIAS and slowly retract the flaps.

For a soft field takeoff without an obstacle to clear, extend the flaps 25°, accelerate the airplane and lift the nose gear off as soon as possible. Lift off at the lowest possible airspeed. Accelerate just above the ground to the best rate of climb speed, 79 KIAS, and retract the flaps while climbing out.

4.25 CLIMB

The best rate of climb at gross weight will be obtained at 79 KIAS. The best angle of climb may be obtained at 63 KIAS. At lighter than gross weight these speeds are reduced somewhat. For climbing en route, a speed of 87 KIAS is recommended. This will produce better forward speed and increased visibility over the nose during the climb.

When reaching the desired altitude, the electric fuel pump may be turned off.

4.27 CRUISE

The cruising efficiency and speed is determined by many factors, including power setting, altitude, temperature, loading and equipment installed in the airplane.

The normal cruising power is 55% to 75% of the rated horsepower of the engine. Airspeeds which may be obtained at various altitudes and power settings can be determined from the performance graphs provided by Section 5.

Use of the mixture control in cruising flight significantly reduces fuel consumption while reducing lead deposits when alternate fuels are used. The mixture should be full rich when operating above 75% power, and leaned during cruising operation when 75% power or less is being used.

To lean the mixture for best power cruise performance place the mixture control full forward and set the throttle slightly below (approximately 35 RPM) the desired cruise power setting and lean the mixture to peak RPM. Adjust the throttle, if necessary, for final RPM setting.

For Best Economy cruise, a simplified leaning procedure which consistently allows accurate achievement of best engine efficiency has been developed. Best Economy Cruise performance is obtained with the throttle fully open. To obtain a desired cruise power setting, set the throttle and mixture control full forward, taking care not to exceed the engine speed limitation, then begin leaning the mixture. The RPM will increase slightly but will then begin to decrease. Continue leaning until the desired cruise engine RPM is reached. This will provide best fuel economy and maximum miles per gallon for a given power setting. See following CAUTION when using this procedure.

CAUTION

Prolonged operation at powers above 75% with a leaned mixture can result in engine damage. While establishing Best Economy Cruise Mixture, below 6,000 feet, care must be taken not to remain in the range above 75% power more than 15 seconds while leaning. Above 6,000 feet the engine is incapable of generating more than 75%.

Always remember that the electric fuel pump should be turned ON before switching tanks, and should be left on for a short period thereafter. In order to keep the airplane in best lateral trim during cruising flight, the fuel should be used alternately from each tank. It is recommended that one tank be used for one hour after takeoff, then the other tank be used for two hours; then return to the first tank, which will have approximately one and one half hours of fuel remaining if the tanks were full at takeoff. The second tank will contain approximately one half hour of fuel. Do not run tanks completely dry in flight. The electric fuel pump should be normally OFF, so that any malfunction of the engine driven fuel pump is immediately apparent. If signs of fuel starvation should occur at any time during flight, fuel exhaustion should be suspected, at which time the fuel selector should be immediately positioned to the other tank and the electric fuel pump switched to the ON position.

4.29 DESCENT

NORMAL

To achieve the performance on Figure 5-31, a power on descent must be used. The throttle should be set for 2500 RPM, mixture full rich and maintain an airspeed of 126 KIAS. In case carburetor ice is encountered apply full carburetor heat.

POWER OFF

If a prolonged power off descent is to be made, apply full carburetor heat prior to power reduction if icing conditions are suspected,. Throttle should be retarded and mixture control leaned as required. Power response should be verified approximately every 30 seconds by partially opening and then closing the throttle (clearing the engine). When leveling off, enrichen mixture, set power as required and select carburetor heat off unless carburetor icing conditions are suspected.

4.31 APPROACH AND LANDING (See charts in Section 5)

Check to insure the fuel selector is on the proper (fullest) tank and that the seat backs are erect. The seat belts and shoulder harnesses should be fastened and the inertia reel checked.

Turn the electric fuel pump ON. The mixture should be set in the full RICH position.

The airplane should be trimmed to an initial-approach speed of about 70 KIAS with a final-approach speed of 63 KIAS with flaps extended to 40°. The flaps can be lowered at speeds up to 103 KIAS, if desired.

The mixture control should be kept in full RICH position to insure maximum acceleration if it should be necessary to open the throttle again. Carburetor heat should not be applied unless there is an indication of carburetor icing, since the use of carburetor heat causes a reduction in power which may be critical in case of a go-around. Full throttle operation with carburetor heat on can cause detonation.

The amount of flap used during landings and the speed of the aircraft at contact with the runway should be varied according to the landing surface and conditions of wind and airplane loading. It is generally good practice to contact the ground at the minimum possible safe speed consistent with existing conditions.

Normally, the best technique for short and slow landings is to use full flap and enough power to maintain the desired airspeed and approach flight path. Mixture should be full RICH, fuel on the fullest tank, and electric fuel pump ON. Reduce the speed during the flareout and contact the ground close to the stalling speed. After ground contact hold the nose wheel off as long as possible. As the airplane slows down, gently lower the nose and apply the brakes. Braking is most effective when flaps are raised and back pressure is applied to the control wheel, putting most of the aircraft weight on the main wheels. In high wind conditions, particularly in strong cross-winds, it may be desirable to approach the ground at higher than normal speeds with partial or no flaps.

4.33 STOPPING ENGINE

At the pilot's discretion, the flaps should be raised and the electric fuel pump turned OFF. The radios should be turned OFF, and the engine stopped by disengaging the mixture control lock and pulling the mixture control back to idle cut-off. The throttle should be left full aft to avoid engine vibration while stopping. Then the magneto and master switches must be turned OFF.

NOTE

When alternate fuels are used, the engine should be run up to 1200 RPM for one minute prior to shutdown to clean out any unburned fuel.

NOTE

The flaps must be placed in the UP position for the flap step to support weight. Passengers should be cautioned accordingly.

4.35 PARKING

If necessary, the airplane should be moved on the ground with the aid of the nose wheel tow bar provided with each airplane and secured behind the rear seats. The aileron and stabilator controls should be secured by looping the safety belt through the control wheel and pulling it snug. The flaps are locked when in the UP position and should be left retracted.

Tie downs can be secured to rings provided under each wing and to the tail skid. The rudder is held in position by its connections to the nose wheel steering and normally does not have to be secured.

4.37 STALLS

The stall characteristics are conventional. An approaching stall is indicated by a stall warning horn which is activated between five and ten KTS above stall speed. Mild airframe buffeting and gentle pitching may also precede the stall.

The gross weight stalling speed with power off and full flaps is 44 KIAS. With the flaps up this speed is increased. Loss of altitude during stalls varies from 100 to 275 feet, depending on configuration and power.

NOTE

The stall warning system is inoperative with the master switch OFF.

During preflight, the stall warning system should be checked by turning the master switch ON, lifting the detector and checking to determine if the horn is actuated. The master switch should be returned to the OFF position after the check is complete.

4.39 TURBULENT AIR OPERATION

In keeping with good operating practice used in all aircraft, it is recommended that when turbulent air is encountered or expected, the airspeed be reduced to maneuvering speed to reduce the structural loads caused by gusts and to allow for inadvertent speed build-ups which may occur as a result of the turbulence or of distractions caused by the conditions. (See Subsection 2.3.)

4.41 WEIGHT AND BALANCE

It is the responsibility of the owner and pilot to determine that the airplane remains within the allowable weight vs. center of gravity envelope while in flight.

For weight and balance data, refer to Section 6 (Weight and Balance).

4.43 NOISE LEVEL

The noise level of this aircraft is 72.9 dB(A).

No determination has been made by the Federal Aviation Administration that the noise levels of this airplane are or should be acceptable or unacceptable for operation at, into, or out of, any airport.

The above statement notwithstanding, the noise level stated above has been verified by and approved by the Federal Aviation Administration in noise level test flights conducted in accordance with FAR 36, Noise Standards - Aircraft Type and Airworthiness Certification. This aircraft model is in compliance with all FAR 36 noise standards applicable to this type.

TABLE OF CONTENTS
SECTION 5
PERFORMANCE

Paragraph No.		Page No.
5.1	General	5-1
5.3	Introduction - Performance and Flight Planning.....	5-1
5.5	Flight Planning Example.....	5-3
5.7	Performance Graphs.....	5-9
	List of Figures	5-9

THIS PAGE INTENTIONALLY LEFT BLANK

REPORT: VB-1565

5-ii

**SECTION 5
PERFORMANCE**

5.1 GENERAL

All of the required (FAA regulations) and complementary performance information applicable to this aircraft is provided by this section.

Performance information associated with those optional systems and equipment that require handbook supplements is provided by Section 9 (Supplements).

5.3 INTRODUCTION - PERFORMANCE AND FLIGHT PLANNING

The performance information presented in this section is based on measured Flight Test Data corrected to I.C.A.O. standard day conditions and analytically expanded for the various parameters of weight, altitude, temperature, etc.

The performance charts are unfactored and do not make any allowance for varying degrees of pilot proficiency or mechanical deterioration of the aircraft. This performance, however, can be duplicated by following the stated procedures in a properly maintained airplane.

Effects of conditions not considered on the charts must be evaluated by the pilot, such as the effect of soft or grass runway surface on takeoff and landing performance, or the effect of winds aloft on cruise and range performance. Endurance can be grossly affected by improper leaning procedures, and inflight fuel flow and quantity checks are recommended.

REMEMBER! To get chart performance, follow the chart procedures.

**SECTION 5
PERFORMANCE**

**PIPER AIRCRAFT CORPORATION
PA-28-161, WARRIOR III**

The information provided by paragraph 5.5 (Flight Planning Example) outlines a detailed flight plan using the performance charts in this section. Each chart includes its own example to show how it is used.

WARNING

Performance information derived by extrapolation beyond the limits shown on the charts should not be used for flight planning purposes.

5.5 FLIGHT PLANNING EXAMPLE

NOTE:

The information contained in this Section (5.5) is to be used for example purposes only.

(a) Aircraft Loading

The first step in planning a flight is to calculate the airplane weight and center of gravity by utilizing the information provided by Section 6 (Weight and Balance) of this handbook.

The basic empty weight for the airplane as licensed at the factory has been entered in Figure 6-5. If any alterations to the airplane have been made affecting weight and balance, reference to the aircraft logbook and Weight and Balance Record (Figure 6-7) should be made to determine the current basic empty weight of the airplane.

Make use of the Weight and Balance Loading Form (Figure 6-11) and the C.G. Range and Weight graph (Figure 6-15) to determine the total weight of the airplane and the center of gravity position.

After proper utilization of the information provided, the following weights apply to the flight planning example.

The landing weight cannot be determined until the weight of the fuel to be used has been established [refer to item (g)(1)].

(1) Basic Empty Weight	1406 lbs.
(2) Occupants (4 x 170 lbs.)	680 lbs.
(3) Baggage and Cargo	50 lbs.
(4) Fuel (6 lb/gal x 30)	180 lbs.
(5) Takeoff Weight	2316 lbs.
(6) Landing Weight	
(a)(5) minus (g)(1), (2316 lbs.	
minus 188.4 lbs.	2127.6 lbs.

The takeoff weight is below the maximum of 2440 lbs., and the weight and balance calculations have determined that the C.G. position is within the approved limits.

**SECTION 5
PERFORMANCE**

**PIPER AIRCRAFT CORPORATION
PA-28-161, WARRIOR III**

(b) Takeoff and Landing

Now that the aircraft loading has been determined, all aspects of the takeoff and landing must be considered.

All of the existing conditions at the departure and destination airport must be acquired, evaluated and maintained throughout the flight.

Apply the departure airport conditions and takeoff weight to the appropriate Takeoff Performance graph (Figures 5-7 and 5-9 or 5-11 and 5-13) to determine the length of runway necessary for the takeoff and/or the barrier distance.

The landing distance calculations are performed in the same manner using the existing conditions at the destination airport and, when established, the landing weight.

The conditions and calculations for the example flight are listed below. The takeoff and landing distances required for the example flight have fallen well below the available runway lengths.

	Departure Airport	Destination Airport
(1) Pressure Altitude	1500 ft.	2500 ft.
(2) Temperature	27°C	24°C
(3) Wind Component	15 KTS (Headwind)	0 KTS
(4) Runway Length Available	4800 ft.	7600 ft.
(5) Runway Required	2100 ft.*	1105 ft.**

NOTE

The remainder of the performance charts used in this flight planning example assume a no wind condition. The effect of winds aloft must be considered by the pilot when computing climb, cruise and descent performance.

*reference Figure 5-9

**reference Figure 5-35

(c) Climb

The next step in the flight plan is to determine the necessary climb segment components.

The desired cruise pressure altitude and corresponding cruise outside air temperature values are the first variables to be considered in determining the climb components from the Fuel, Time and Distance to Climb graph (Figure 5-19). After the fuel, time and distance for the cruise pressure altitude and outside air temperature values have been established, apply the existing conditions at the departure field to graph (Figure 5-19). Now, subtract the values obtained from the graph for the field of departure conditions from those for the cruise pressure altitude.

The remaining values are the true fuel, time and distance components for the climb segment of the flight plan corrected for field pressure altitude and temperature.

The following values were determined from the above instructions in the flight planning example.

(1) Cruise Pressure Altitude	5000 ft.
(2) Cruise OAT	16°C
(3) Time to Climb (11.0 min. minus 3.0 min.)	8.0 min.*
(4) Distance to Climb (16.0 miles minus 3.0 miles)	13.0 miles*
(5) Fuel to Climb (3 gal. minus 1.0 gal.)	2.0 gal.*

(d) Descent

The descent data will be determined prior to the cruise data to provide the descent distance for establishing the total cruise distance.

Utilizing the cruise pressure altitude and OAT, determine the basic fuel, time and distance for descent (Figure 5-31). These figures must be adjusted for the field pressure altitude and temperature at the destination airport. To find the necessary adjustment values, use the existing pressure altitude and temperature conditions at the destination airport as variables to find the fuel, time and distance

*reference Figure 5-19

**SECTION 5
PERFORMANCE**

**PIPER AIRCRAFT CORPORATION
PA-28-161, WARRIOR III**

values from the graph (Figure 5-31). Now, subtract the values obtained from the field conditions from the values obtained from the cruise conditions to find the true fuel, time and distance values needed for the flight plan.

The values obtained by proper utilization of the graphs for the descent segment of the example are shown below.

(1) Time to Descend (8.8 min. minus 4.9 min.)	9.0 min.*
(2) Distance to Descend (19.6 miles minus 11.0 miles)	8.6 miles*
(3) Fuel to Descend (1.9 gal. minus 1.0 gal.)	.9 gal.*

(e) Cruise

Using the total distance to be traveled during the flight, subtract the previously calculated distance to climb and distance to descend to establish the total cruise distance. Refer to the appropriate Avco Lycoming Operator's Manual when selecting the cruise power setting. The established pressure altitude and temperature values and the selected cruise power should now be utilized to determine the true airspeed from the Cruise Performance graph (Figure 5-21 or 5-23).

Calculate the cruise fuel consumption for the cruise power setting from the information provided by the Avco Lycoming Operator's Manual.

The cruise time is found by dividing the cruise distance by the cruise speed and the cruise fuel is found by multiplying the cruise fuel consumption by the cruise time.

The cruise calculations established for the cruise segment of the flight planning example are as follows:

(1) Total Distance	300 miles
(2) Cruise Distance (e)(1) minus (c)(4) minus (d)(2), (300 minus 13 miles minus 8.6 miles)	278.4 miles

*reference Figure 5-31

(3) Cruise Power Best Power Mixture	75% rated power (2665 RPM)
(4) Cruise Speed	114 KTS TAS*
(5) Cruise Fuel Consumption	11.4 GPH
(6) Cruise Time (e)(2) divided by (e)(4), (278.4 miles divided by 114 KTS)	2.44 hrs.
(7) Cruise Fuel (e)(5) multiplied by (e)(6), (11.4 GPH multiplied by 2.50 hrs.)	28.5 gal.

(f) Total Flight Time

The total flight time is determined by adding the time to climb, the time to descend and the cruise time. Remember! The time values taken from the climb and descent graphs are in minutes and must be converted to hours before adding them to the cruise time.

The following flight time is required for our flight planning example.

(1) Total Flight Time (c)(3) plus (d)(1) plus (e)(6), (.13 hrs. plus .07 hrs. plus 2.44 hrs.)	2.64 hrs.
---	-----------

(g) Total Fuel Required

Determine the total fuel required by adding the fuel to climb, the fuel to descend and the cruise fuel. When the total fuel (in gallons) is determined, multiply this value by 6 lb/gal. to determine the total fuel weight used for the flight.

The total fuel calculations for the example flight plan are shown below.

(1) Total Fuel Required (c)(5) plus (d)(3) plus (e)(7), (2.0 gal. plus .9 gal. plus 28.5 gal.) (31.4 gal. multiplied by 6 lb/gal.)	31.4 gal. 188.4 lbs.
---	-------------------------

*reference Figure 5-23b

THIS PAGE INTENTIONALLY LEFT BLANK

5.7 PERFORMANCE GRAPHS

LIST OF FIGURES

Figure No.		Page No.
5-1	Temperature Conversion.....	5-11
5-3	Airspeed System Calibration.....	5-12
5-5	Stall Speed.....	5-13
5-7	0° Flaps Takeoff Ground Roll	5-14
5-9	0° Flaps Takeoff Performance	5-15
5-11	25° Flaps Takeoff Ground Roll	5-16
5-13	25° Flaps Takeoff Performance	5-17
5-15	Engine Performance	5-18
5-17	Climb Performance	5-19
5-19	Fuel, Time and Distance to Climb.....	5-20
5-21	Cruise Performance- Speed Power.....	5-20b
5-23	Engine & Cruise Performance- 55% Power.....	5-21
5-23a	Engine & Cruise Performance- 65% Power.....	5-21
5-23b	Engine & Cruise Performance- 75% Best Power.....	5-23
5-25	Range.....	5-24
5-29	Endurance.....	5-25
5-31	Fuel, Time and Distance to Descend.....	5-26
5-33	Glide Performance.....	5-27
5-35	Landing Distance.....	5-28
5-37	Landing Ground Roll Distance	5-29

THIS PAGE INTENTIONALLY LEFT BLANK

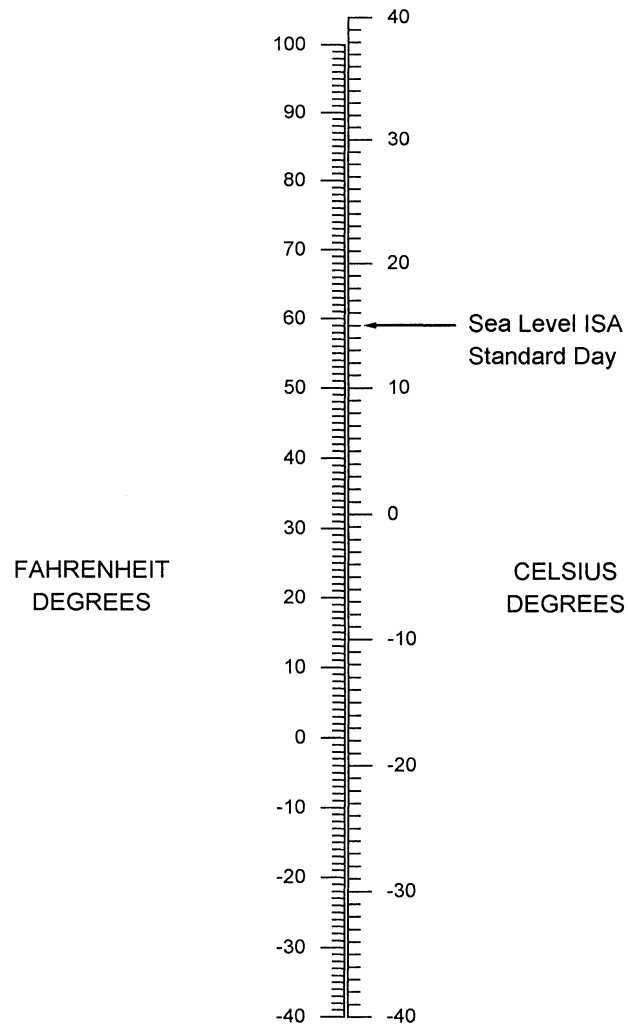

TEMPERATURE CONVERSION

Figure 5-1

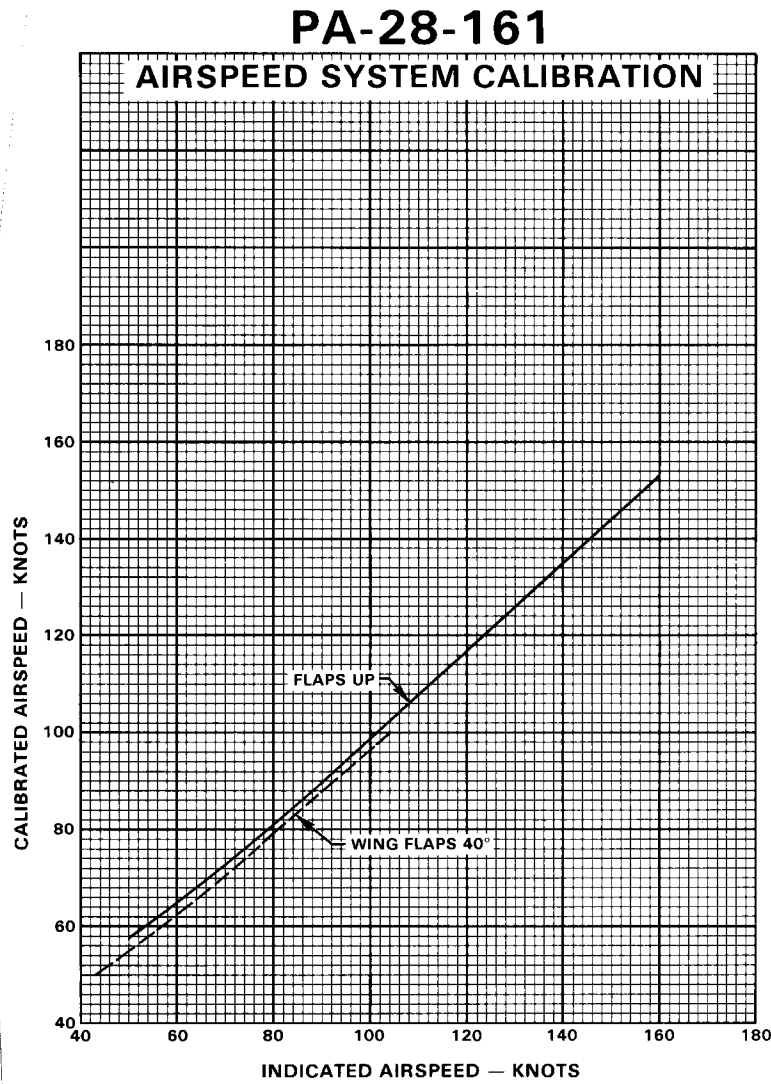

AIRSPEED SYSTEM CALIBRATION
Figure 5-3

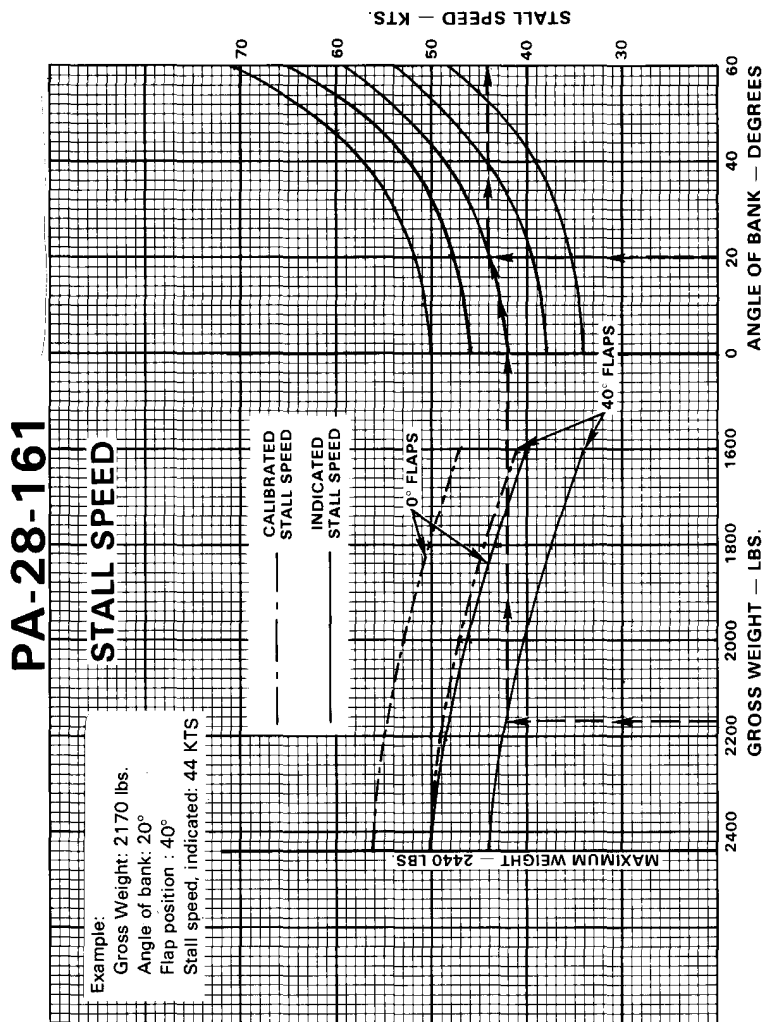

STALL SPEED
 Figure 5-5

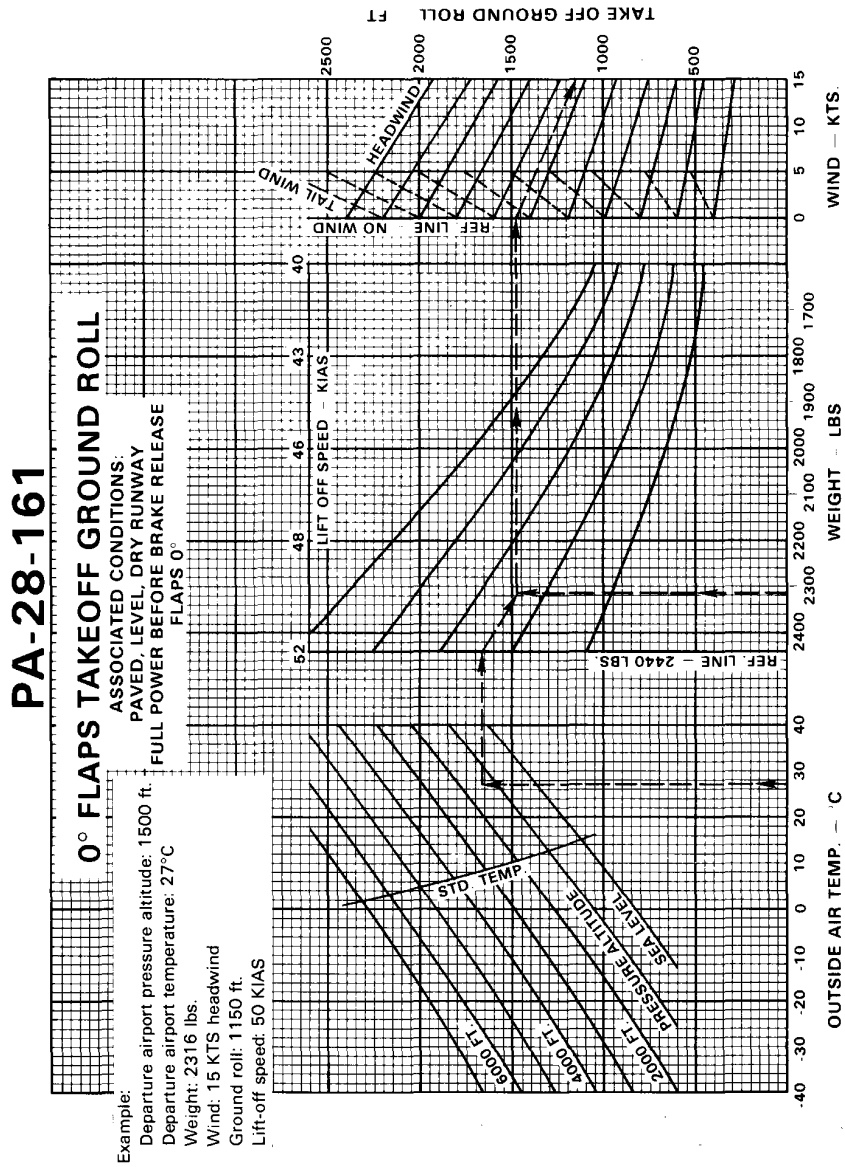

0° FLAPS TAKEOFF GROUND ROLL

Figure 5-7

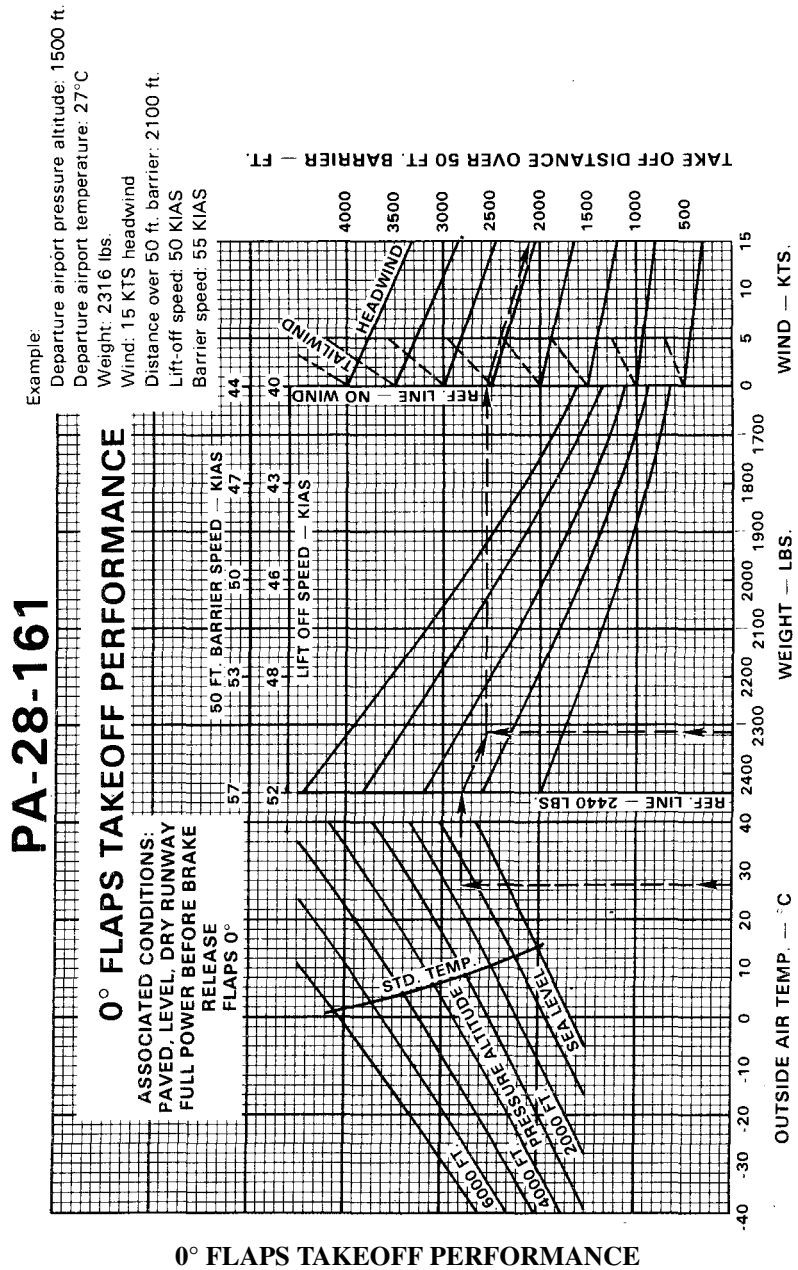
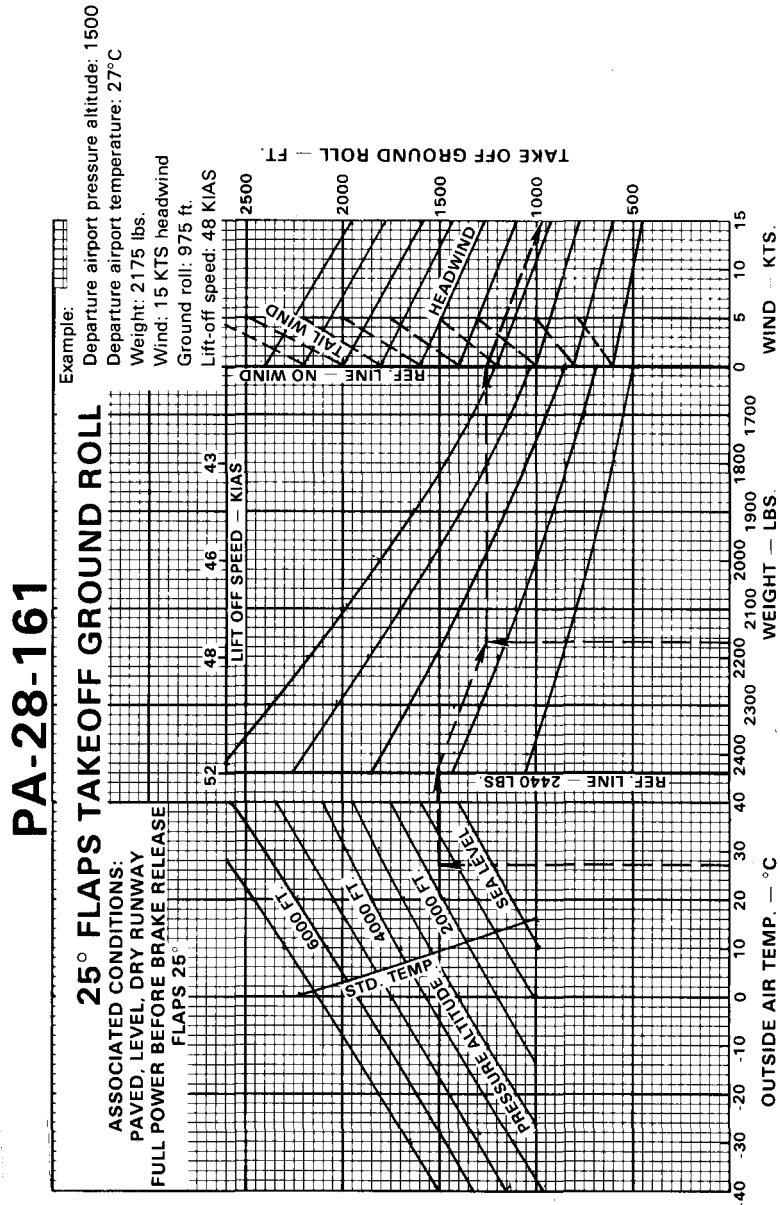

Figure 5-9



25° FLAPS TAKEOFF GROUND ROLL

Figure 5-11

PA-28-161

25° FLAPS TAKEOFF PERFORMANCE

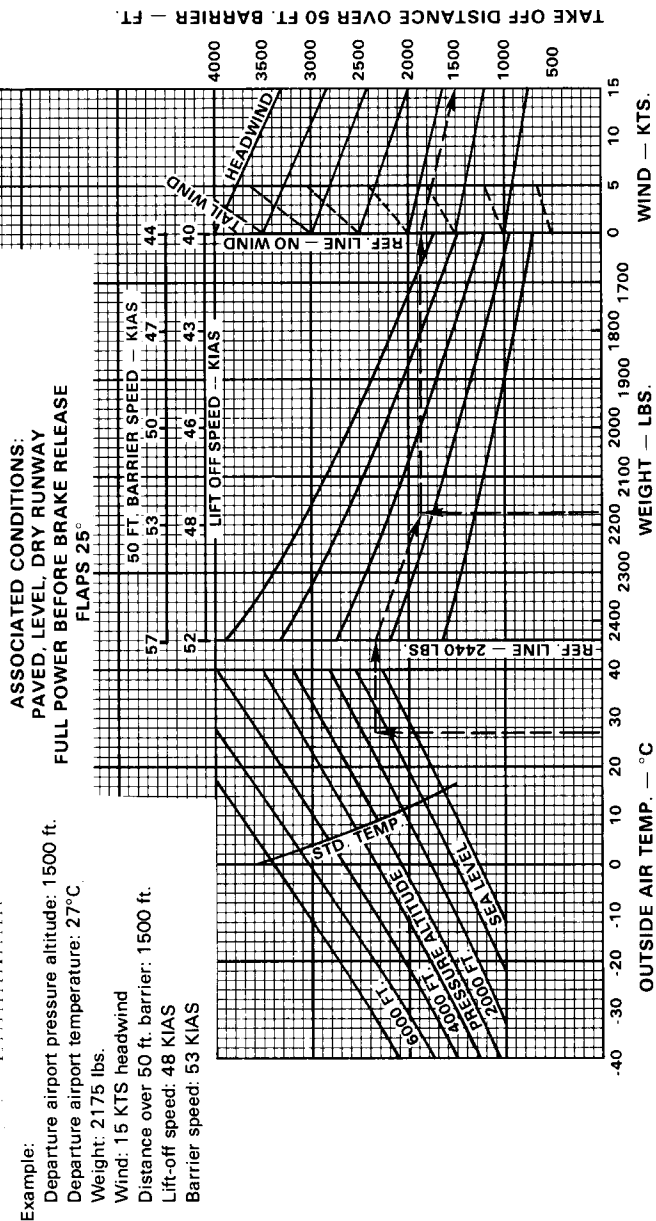

25° FLAPS TAKEOFF PERFORMANCE

Figure 5-13

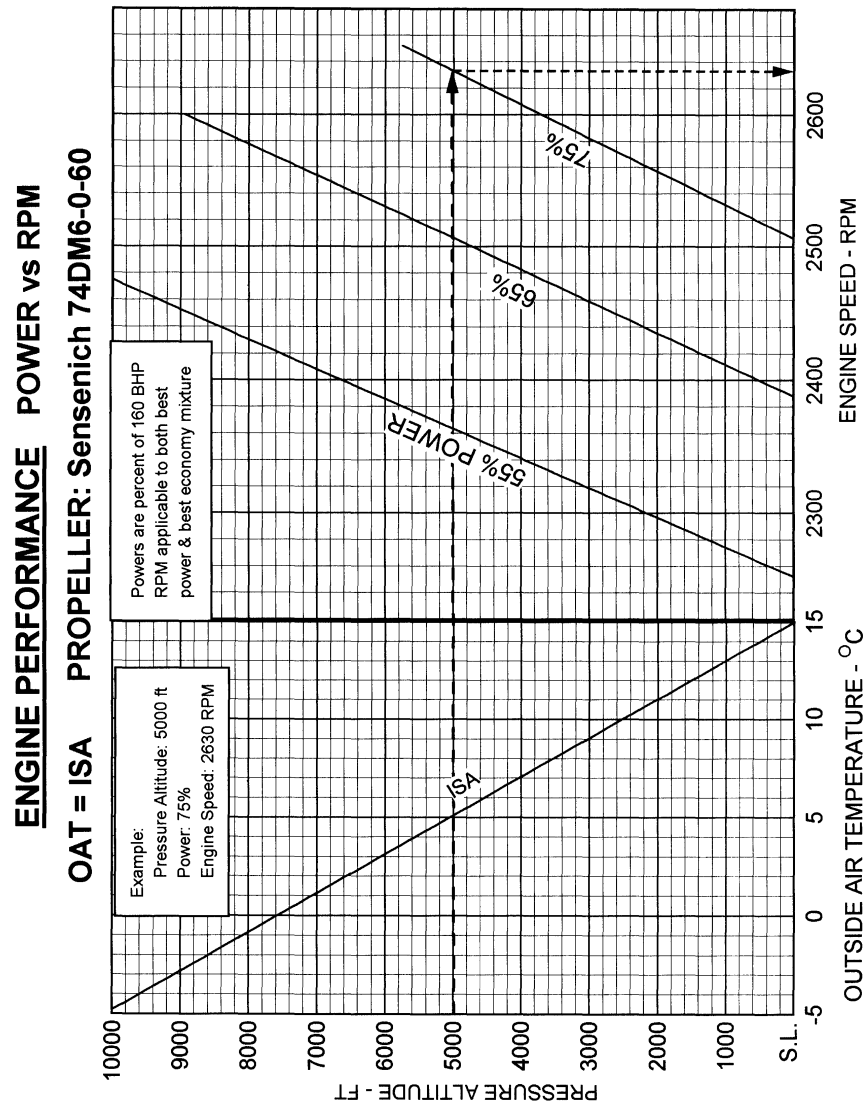

ENGINE PERFORMANCE
Figure 5-15

MAXIMUM RATE OF CLIMB

ASSOCIATED CONDITIONS:

GROSS WEIGHT: 2440 lb.
 POWER: FULL THROTTLE
 MIXTURE: FULL RICH
 FLAPS: UP
 AIRSPEED: 79 KIAS

EXAMPLE
 PRESSURE ALTITUDE: 5000FT
 OAT: 16° C (ISA + 11° C)
 MAX RATE OF CLIMB: 374 FPM

PRESSURE ALTITUDE FEET	OUTSIDE AIR TEMPERATURE				
	ISA - 15° C	ISA	ISA + 10° C	ISA + 20° C	ISA + 30° C
S.L.	677	644	624	604	585
1000	628	595	574	554	534
2000	578	545	524	504	485
3000	528	495	475	455	436
4000	478	446	425	405	386
5000	429	396	376	356	337
6000	379	346	326	306	287
7000	330	298	277	257	238
8000	280	248	227	207	188
9000	231	198	177	157	138
10000	181	149	128	108	89
11000	132	99	79	59	40
12000	83	49	29	9	-10
13000	33	0	-21	-41	-60

CLIMB PERFORMANCE

Figure 5-17

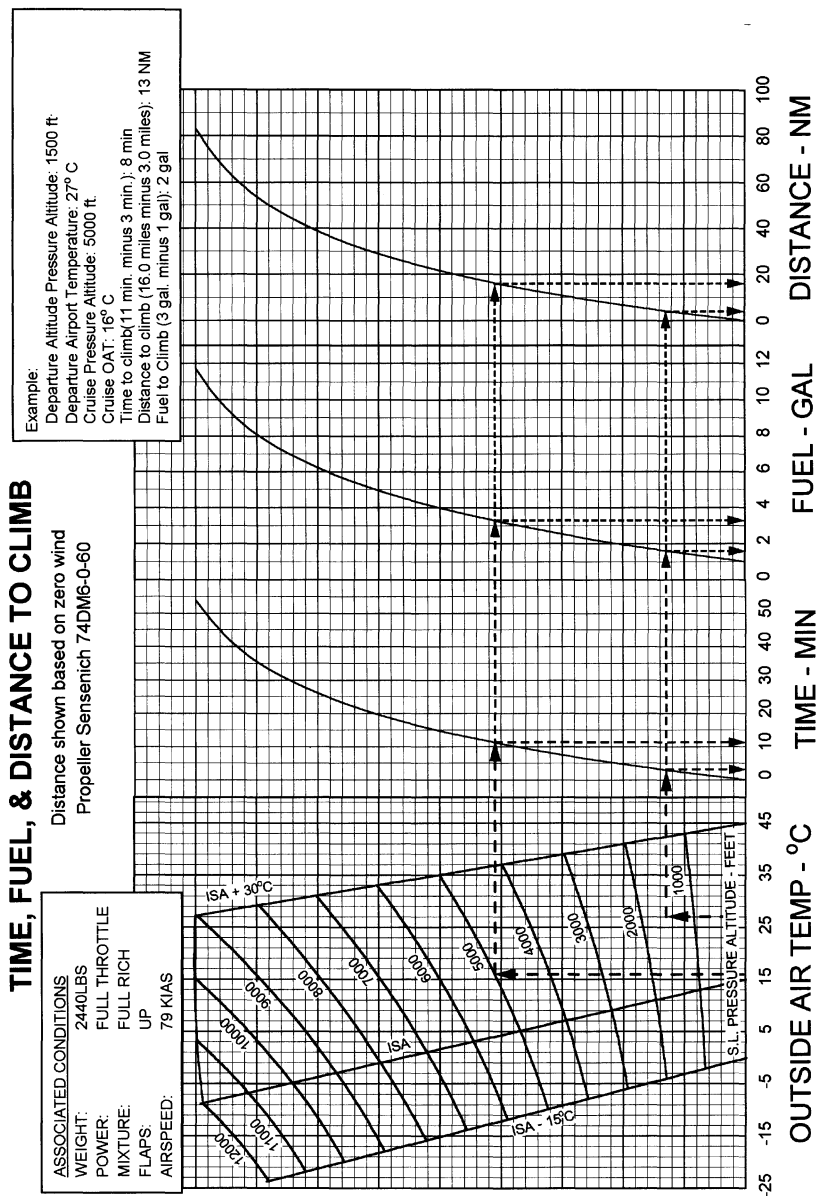
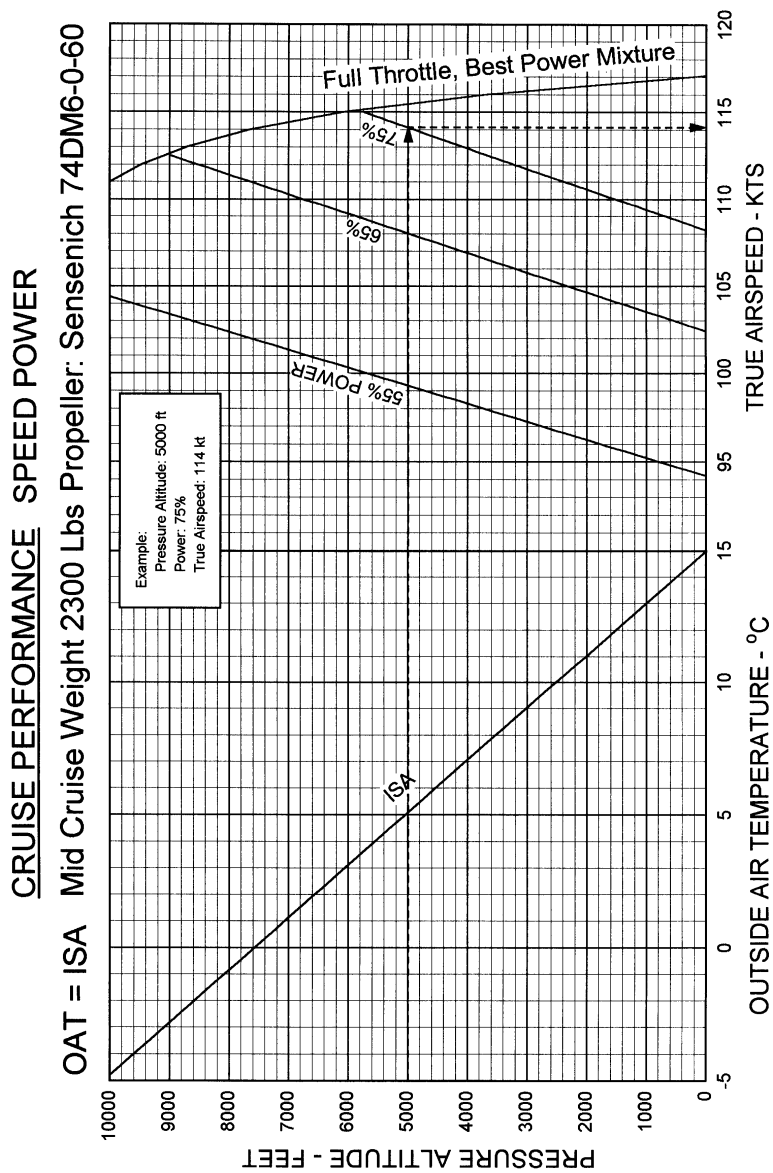

Figure 5-19

THIS PAGE INTENTIONALLY LEFT BLANK

**ISSUED: JULY 1, 1994
REVISED: JUNE 9, 1995**

**REPORT: VB-1565 |
5-20a**



CRUISE PERFORMANCE - SPEED POWER

Figure 5-21

Engine & Cruise Performance for Non-ISA OAT
RPM for Constant 55% Power
Fuel Flow: Best Economy Mixture 7.9 GPH

Pressure Altitude Feet	Indicated Outside Air Temperature			Engine Speed RPM	True Air Speed Knots
	°C	°C	°F		
Sea Level	ISA -15	0	32	2210	92
	ISA	15	59	2250	
	ISA +10	25	77	2280	
	ISA +20	35	95	2300	
	ISA +30	45	113	2330	
2000	ISA -15	-4	25	2260	94
	ISA	11	52	2300	
	ISA +10	21	70	2320	
	ISA +20	31	88	2350	
	ISA +30	41	106	2370	
4000	ISA -15	-8	18	2300	96
	ISA	7	45	2340	
	ISA +10	17	63	2370	
	ISA +20	27	81	2400	
	ISA +30	37	99	2420	
6000	ISA -15	-12	10	2350	98
	ISA	3	37	2390	
	ISA +10	13	55	2410	
	ISA +20	23	73	2440	
	ISA +30	33	91	2460	
8000	ISA -15	-16	4	2390	100
	ISA	-1	31	2430	
	ISA +10	9	49	2460	
	ISA +17.5	16.5	62	2475	
9000	ISA -15	-18	0	2410	101
	ISA	-3	27	2450	
	ISA +8.5	5.5	42	2480	
10000	ISA -15	-20	-3	2430	102
	ISA	-5	24	2480	

Example:

Cruise Altitude: 5000 ft
Cruise Temperature: 16° C (ISA + 11° C)
Engine Speed: 2390 RPM (By Interpolation)

ENGINE & CRUISE PERFORMANCE - 55% POWER

Figure 5-23

**SECTION 5
PERFORMANCE**

**PIPER AIRCRAFT CORPORATION
PA-28-161, WARRIOR III**

**Engine & Cruise Performance for Non-ISA OAT
RPM for Constant 65% Power
Fuel Flow: Best Economy Mixture 9.2 GPH**

Pressure Altitude	Indicated Outside Air Temperature			Engine Speed	True Air Speed
	Feet	°C	°C		
Sea Level	ISA -15	0	32	2340	100
	ISA	15	59	2390	
	ISA +10	25	77	2420	
	ISA +20	35	95	2440	
	ISA +30	45	113	2470	
2000	ISA -15	-4	25	2390	103
	ISA	11	52	2440	
	ISA +10	21	70	2460	
	ISA +20	31	88	2490	
	ISA +30	41	106	2520	
4000	ISA -15	-8	18	2440	105
	ISA	7	45	2480	
	ISA +10	17	63	2510	
	ISA +20	27	81	2540	
	ISA +30	37	99	2560	
6000	ISA -15	-12	10	2490	107
	ISA	3	37	2530	
	ISA +10	13	55	2560	
	ISA +20	23	73	2580	
	ISA +30	33	91	2600	
8000	ISA -15	-16	4	2530	109
	ISA	-1	31	2580	
	ISA +10	9	49	2610	
	ISA +17.5	16.5	62	2630	
9000	ISA -15	-18	0	2560	110
	ISA	-3	27	2600	
	ISA +8.5	5.5	42	2630	
10000	ISA -15	-20	-3	2580	112

Example:

Cruise Altitude: 5000 ft
 Cruise Temperature: 16° C (ISA + 11° C)
 Engine Speed: 2540 RPM (By Interpolation)

ENGINE & CRUISE PERFORMANCE - 65% POWER

Figure 5-23a

**Engine & Cruise Performance for Non-ISA OAT
RPM for Constant 75% Power
Fuel Flow: Best Power Mixture 11.4 GPH**

Pressure Altitude Feet	Indicated Outside Air Temperature			Engine Speed	True Air Speed
	°C	°C	°F	RPM	Knots
Sea Level	ISA -15	0	32	2460	106
	ISA	15	59	2510	
	ISA +10	25	77	2540	
	ISA +20	35	95	2560	
	ISA +30	45	113	2590	
2000	ISA -15	-4	25	2510	108
	ISA	11	52	2560	
	ISA +10	21	70	2590	
	ISA +20	31	88	2620	
	ISA +30	41	106	2640	
3000	ISA -15	-6	21	2540	109
	ISA	9	48	2580	
	ISA +10	19	66	2610	
	ISA +20	29	84	2640	
	ISA +30	39	102	2670	
4000	ISA -15	-8	18	2560	110
	ISA	7	45	2610	
	ISA +10	17	63	2640	
	ISA +20	27	81	2670	
	ISA +30	37	99	2690	
5000	ISA -15	-10	14	2590	112
	ISA	5	41	2630	114
	ISA +10	15	59	2660	-
	ISA +20	25	77	2690	-
6000	ISA -15	-12	10	2610	113
	ISA	3	37	2660	-
	ISA +10	13	55	2690	-
7000	ISA -15	-14	6.8	2640	114
	ISA	1	34	2690	-

Example:

Cruise Altitude: 5000 ft
Cruise Temperature: 16° C (ISA + 11° C)
Engine Speed: 2665 RPM (By Interpolation)

ENGINE & CRUISE PERFORMANCE - 75% BEST POWER

Figure 5-23b

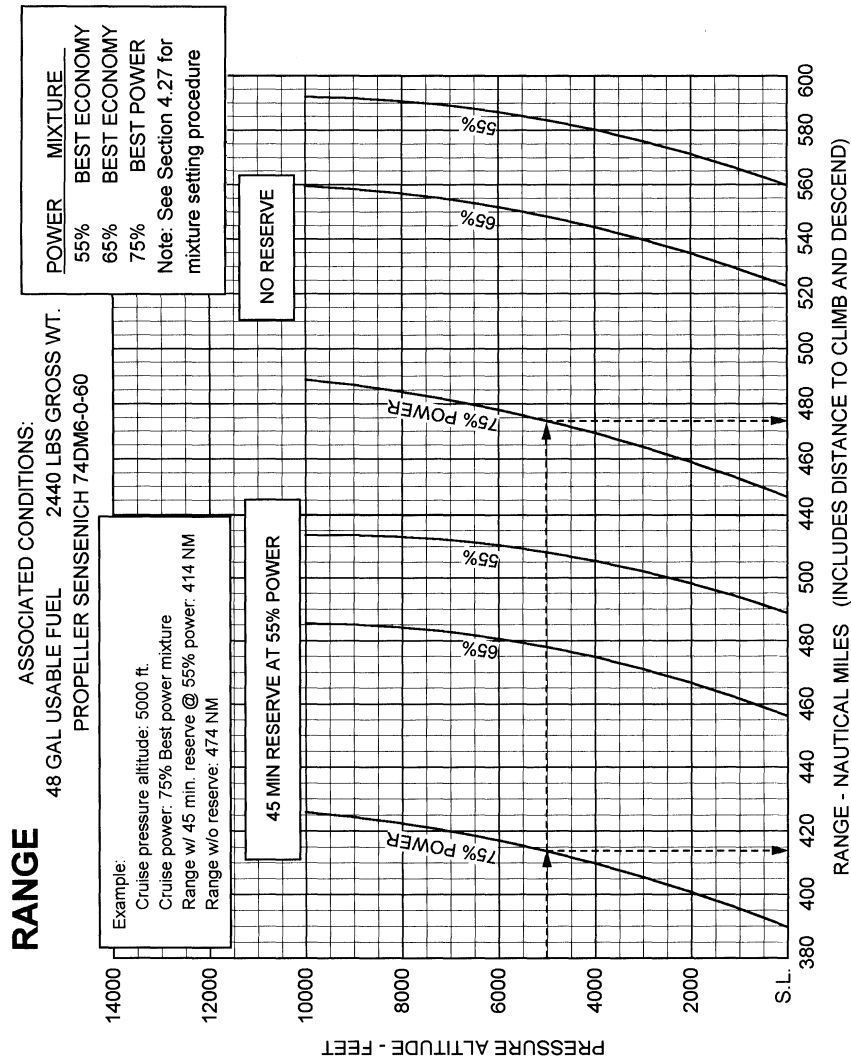

RANGE
Figure 5-25

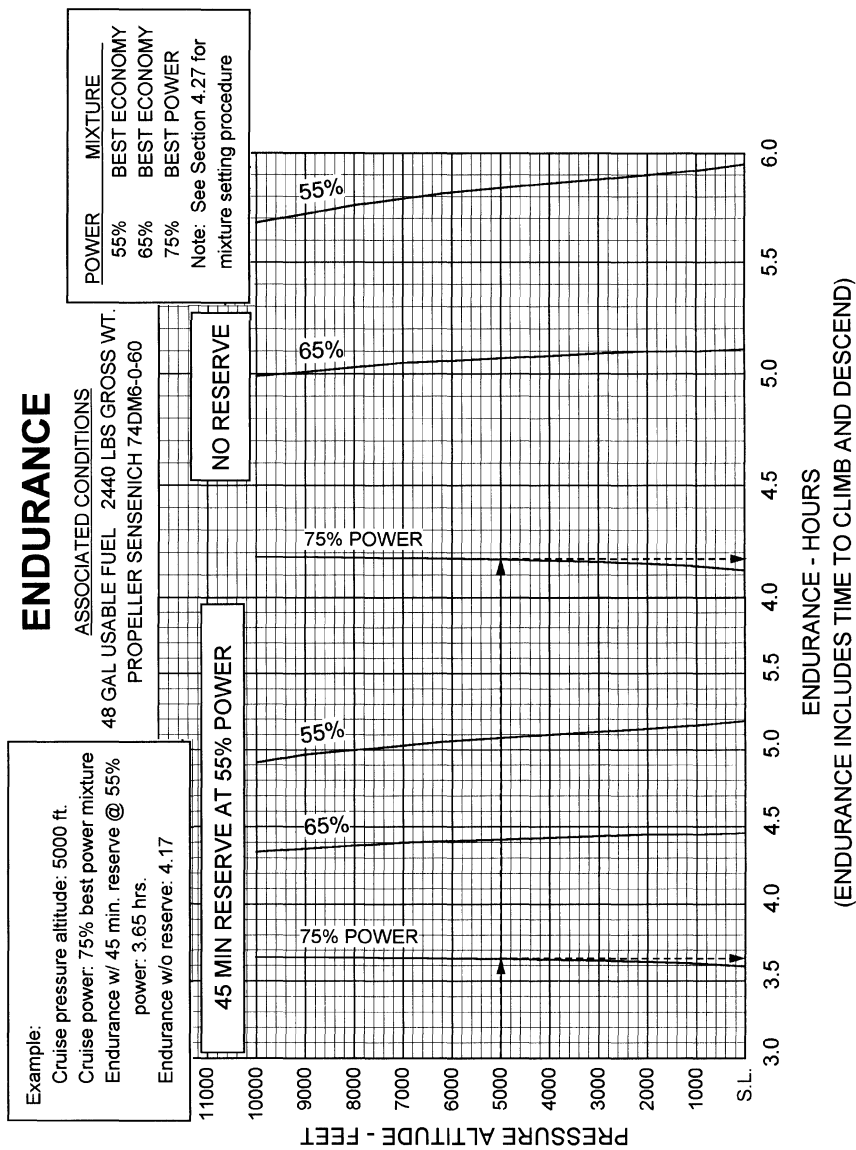

ENDURANCE

Figure 5-29

ISSUED: JULY 1, 1994
 REVISED: JUNE 9, 1995

REPORT: VB-1565
 5-25

PRESSURE ALTITUDE FEET	ISA - 15° C						ISA ° C						ISA + 10° C						ISA + 20° C						ISA + 30° C						
	TIME		FUEL		DIST		TIME		FUEL		DIST		TIME		FUEL		DIST		TIME		FUEL		DIST		TIME		FUEL		DIST		
	MIN		GAL		NM		MIN		GAL		NM		MIN		GAL		NM		MIN		GAL		NM		MIN		GAL		NM		
0	0	0	0	0	0	0	0	0	0	0	0	0	0	0	0	0	0	0	0	0	0	0	0	0	0	0	0	0	0	0	
1000	8	2	4	16	5	1	10	3	1	6	2	1	4	1	1	4	1	1	3	1	1	1	1	1	1	1	1	1	1	1	3
2000	21	4	43	43	8	2	17	5	1	10	3	1	8	1	1	8	1	1	6	1	1	1	1	1	1	1	1	1	1	6	
3000	26	4	53	53	10	2	22	6	1	14	5	1	11	4	1	11	4	1	9	4	1	1	1	1	4	1	1	9	9		
4000	29	5	59	59	12	2	26	8	2	17	6	1	13	5	1	13	5	1	11	5	1	1	1	1	5	1	1	11	11		
5000	31	5	64	64	14	2	29	9	2	20	7	1	16	6	1	16	6	1	13	6	1	1	1	1	6	1	1	13	13		
6000	33	5	67	67	15	3	32	10	2	22	8	2	18	7	1	18	7	1	15	7	1	1	1	1	7	1	1	15	15		
7000	34	6	70	70	16	3	34	11	2	24	9	2	20	7	1	20	7	1	17	7	1	1	1	1	7	1	1	17	17		
8000	35	6	73	73	17	3	36	12	2	26	9	2	21	8	2	21	8	2	18	8	2	2	2	2	8	2	2	18	18		
9000	36	6	76	76	18	3	38	13	2	28	10	2	23	9	2	23	9	2	20	9	2	2	2	2	9	2	2	20	20		
10000	37	6	78	78	19	3	40	13	2	30	11	2	25	9	2	25	9	2	21	9	2	2	2	2	9	2	2	21	21		
11000	38	6	80	80	19	3	42	14	2	31	11	2	26	10	2	26	10	2	23	10	2	2	2	2	10	2	2	23	23		
12000	39	6	81	81	20	3	43	15	2	33	12	2	28	10	2	28	10	2	24	10	2	2	2	2	10	2	2	24	24		

TIME, FUEL, AND DISTANCE TO DESCEND
Distance show based on zero wind
Propeller Sensenich 74DM6-0-60

ASSOCIATED CONDITIONS
POWER: 2500 RPM
AIRSPEED: 126 KIAS

FUEL, TIME AND DISTANCE TO DESCEND

Figure 5-31

Example:
Cruise Pressure Altitude: 5000 ft
Cruise Temperature: 16° C (ISA + 11° C)
Time To Descend: 8.8 min (By Interpolation)
Fuel To Descend: 1.9 gal (By Interpolation)
Distance To Descend: 19.6 miles (By Interpolation)
Destination Airport Pressure Altitude: 2500 ft
Destination Airport Temperature: 24° C (ISA + 14° C)

Time To Descend: 4.9 min (By Interpolation)
Fuel To Descend: 1.0 gal
Distance To Descend: 11 miles
Actual Time To Descend From Cruise To Destination Airport (8.8 - 4.9): 3.9 min
Actual Fuel To Descend From Cruise To Destination Airport (1.9 - 1): 0.9 gal
Actual Distance To Descend From Cruise To Destination Airport (19.6 - 11): 8.6 NM

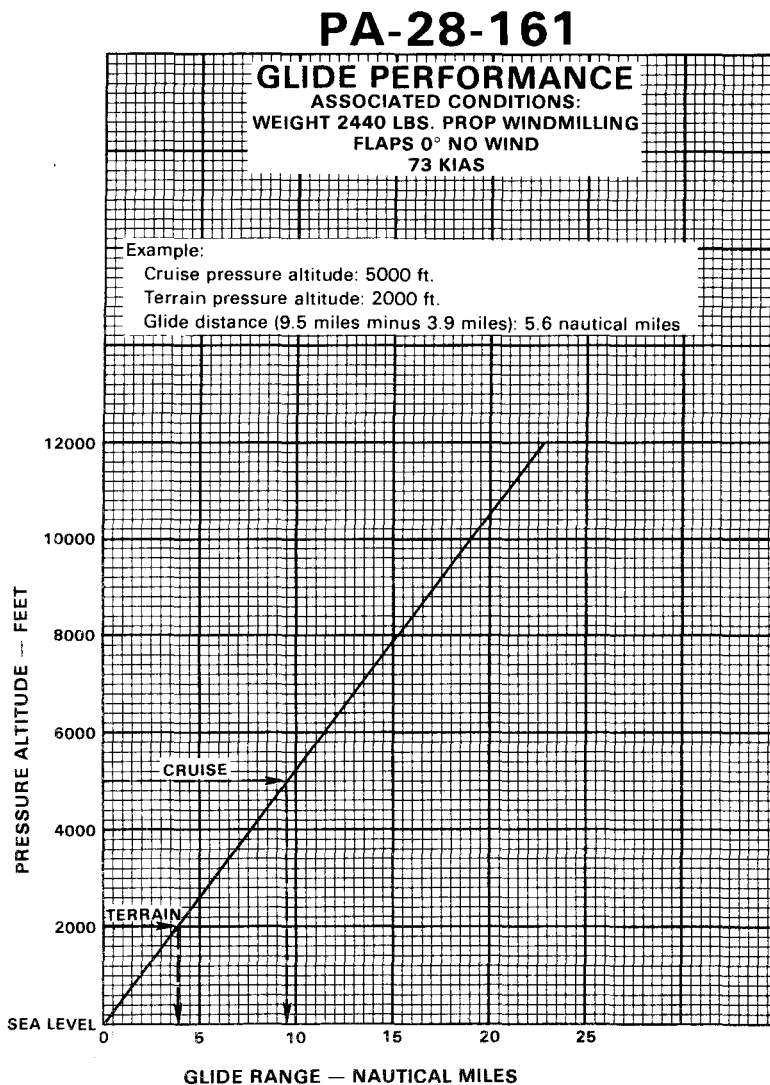

GLIDE PERFORMANCE

Figure 5-33

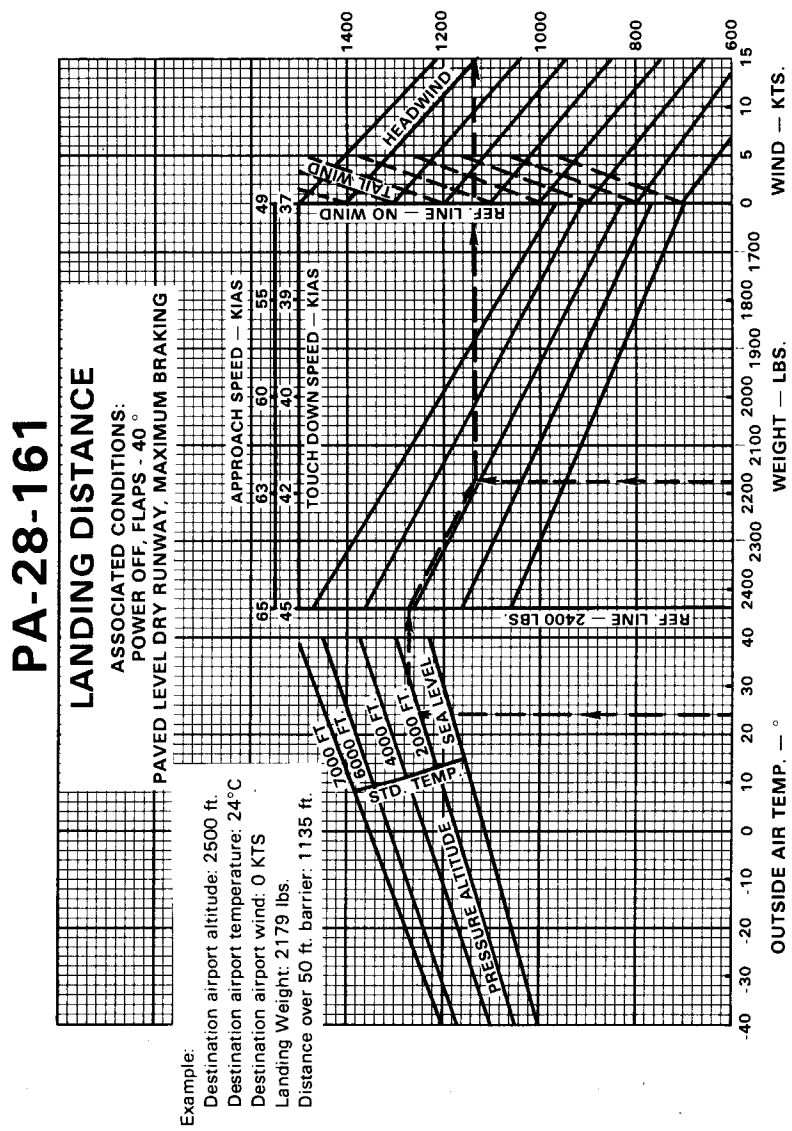

LANDING DISTANCE

Figure 5-35

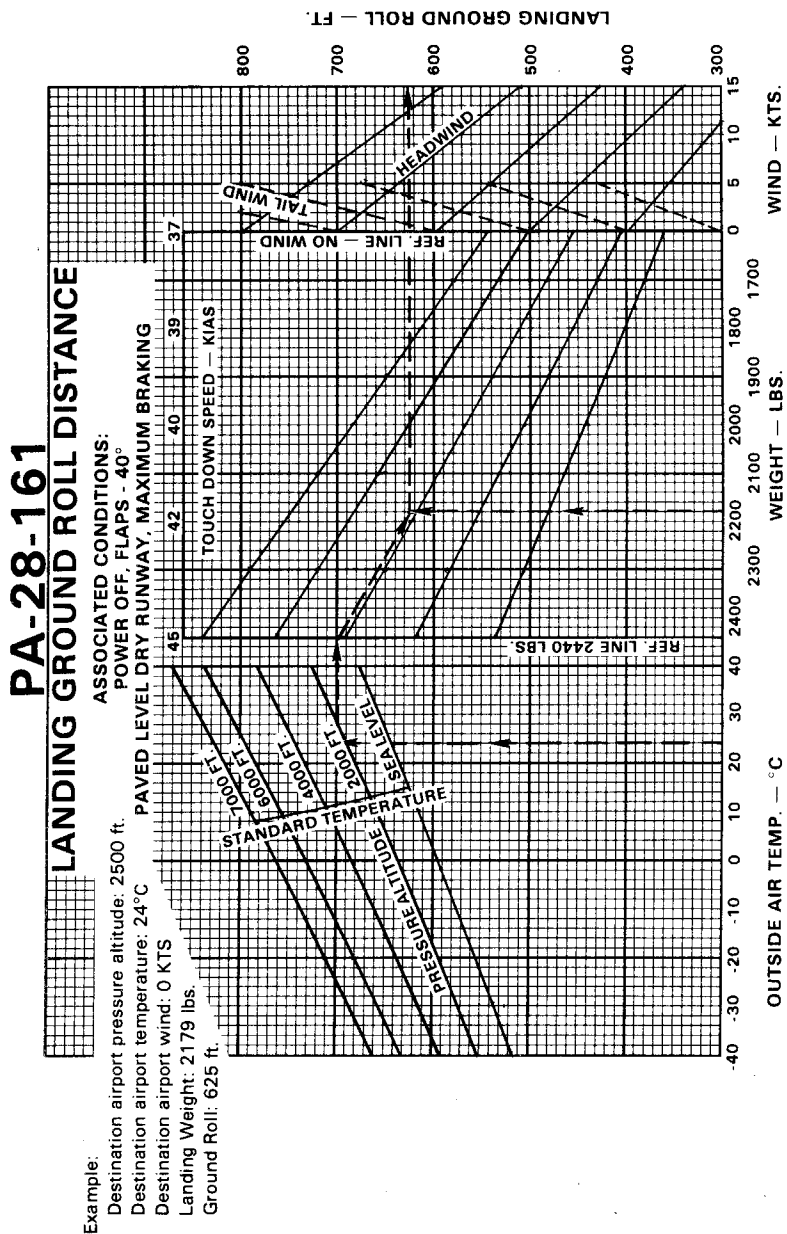

LANDING GROUND ROLL DISTANCE

Figure 5-37

THIS PAGE INTENTIONALLY LEFT BLANK

TABLE OF CONTENTS
SECTION 6
WEIGHT AND BALANCE

Paragraph No.		Page No.
6.1	General	6-1
6.3	Airplane Weighing Procedure	6-2
6.5	Weight and Balance Data and Record	6-6
6.7	Weight and Balance Determination for Flight	6-11
6.9	Instructions for Using the Weight and Balance Plotter	6-15
	Equipment List (Form 240-0009)	Supplied with aircraft paperwork

THIS PAGE INTENTIONALLY LEFT BLANK

**SECTION 6
WEIGHT AND BALANCE**

6.1 GENERAL

In order to achieve the performance and flying characteristics which are designed into the airplane, it must be flown with the weight and center of gravity (C.G.) position within the approved operating range (envelope). Although the airplane offers a flexibility of loading, it cannot be flown with the maximum number of adult passengers, full fuel tanks and maximum baggage. With this loading flexibility comes responsibility. The pilot must insure that the airplane is loaded within the loading envelope before takeoff.

Misloading carries consequences for any aircraft. An overloaded airplane will not take off, climb or cruise as well as a properly loaded one. The heavier the airplane is loaded, the less climb performance it will have.

Center of gravity is a determining factor in flight characteristics. If the C.G. is too far forward in any airplane, it may be difficult to rotate for takeoff or landing. If the C.G. is too far aft, the airplane may rotate prematurely on takeoff or tend to pitch up during climb. Longitudinal stability will be reduced. This can lead to inadvertent stalls and even spins; and spin recovery becomes more difficult as the center of gravity moves aft of the approved limit.

A properly loaded airplane, however, will perform as intended. Before the airplane is licensed, it is weighed, and a basic empty weight and C.G. location is computed (basic empty weight consists of the standard empty weight of the airplane plus the optional equipment). Using the basic empty weight and C.G. location, the pilot can easily determine the weight and C.G. position for the loaded airplane by computing the total weight and moment and then determining whether they are within the approved envelope.

The basic empty weight and C.G. location are recorded in the Weight and Balance Data Form (Figure 6-5) and the Weight and Balance Record (Figure 6-7). The current values should always be used. Whenever new equipment is added or any modification work is done, the mechanic responsible for the work is required to compute a new basic empty weight and C.G. position and to write these in the Aircraft Log Book and the Weight and Balance Record. The owner should make sure that it is done.

A weight and balance calculation is necessary in determining how much fuel or baggage can be loaded so as to keep within allowable limits. Check calculations prior to adding fuel to insure against improper loading.

The following pages are forms used in weighing an airplane in production and in computing basic empty weight, C.G. position, and useful load. Note that the useful load includes usable fuel, baggage, cargo and passengers. Following this is the method for computing takeoff weight and C.G.

6.3 AIRPLANE WEIGHING PROCEDURE

At the time of licensing, Piper Aircraft Corporation provides each airplane with the basic empty weight and center of gravity location. This data is supplied by Figure 6-5.

The removal or addition of equipment or airplane modifications can affect the basic empty weight and center of gravity. The following is a weighing procedure to determine this basic empty weight and center of gravity location:

- (a) Preparation
 - (1) Be certain that all items checked in the airplane equipment list are installed in the proper location in the airplane.
 - (2) Remove excessive dirt, grease, moisture, and foreign items, such as rags and tools, from the airplane before weighing.

- (3) Defuel airplane. Then open all fuel drains until all remaining fuel is drained. Operate engine on each tank until all undrainable fuel is used and engine stops. Then add the unusable fuel (2.0 gallons total, 1.0 gallon each wing).

CAUTION

Whenever the fuel system is completely drained and fuel is replenished, it will be necessary to run the engine for a minimum of three minutes at 1000 RPM on each tank to insure no air exists in the fuel supply lines.

- (4) Fill with oil to full capacity.
- (5) Place pilot and copilot seats in fourth (4th) notch, aft of forward position. Put flaps in fully retracted position and all control surfaces in the neutral position. Tow bar should be in the proper location and all entrance and baggage doors should be closed.
- (6) Weigh the airplane inside a closed building to prevent errors in the scale readings due to wind.

(b) Leveling

- (1) With airplane on scales, block main gear oleo pistons in the fully extended position.
- (2) Level airplane (refer to Figure 6-3) by deflating the nose wheel tire to center bubble on level.

**SECTION 6
WEIGHT AND BALANCE**

**PIPER AIRCRAFT CORPORATION
PA-28-161, WARRIOR III**

(c) Weighing - Airplane Basic Empty Weight

With the airplane level and brakes released, record the weight shown on each scale. Deduct the tare, if any, from each reading.

Scale Position and Symbol	Scale Reading	Tare	Net Weight
Nose Wheel (N)			
Right Main Wheel (R)			
Left Main Wheel (L)			
Basic Empty Weight, (as Weighed) (T)			

WEIGHING FORM

Figure 6-1

(d) Basic Empty Weight Center of Gravity

- (1) The following geometry applies to the PA-28-161 airplane when it is level. Refer to Leveling paragraph 6.3 (b).

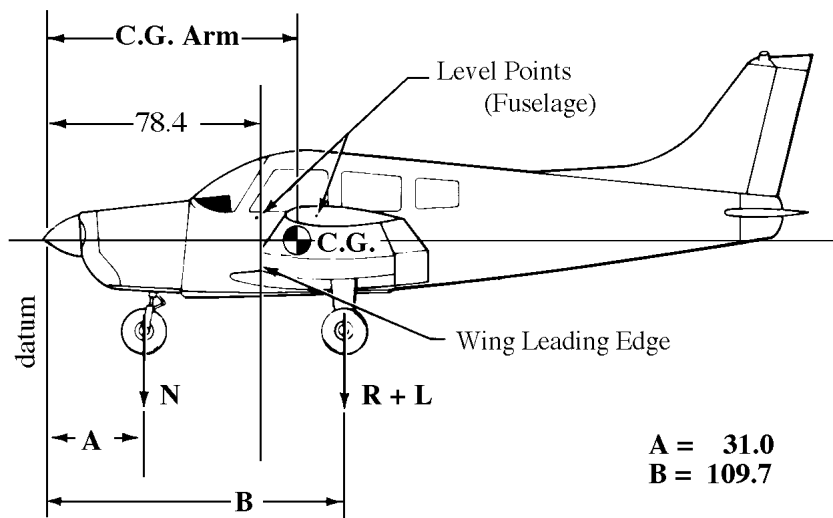

LEVELING DIAGRAM

Figure 6-3

- (2) The basic empty weight center of gravity (as weighed including optional equipment, full oil and unusable fuel) can be determined by the following formula:

$$\text{C.G. Arm} = \frac{N(A) + (R + L)(B)}{T} \text{ inches}$$

Where: $T = N + R + L$

6.5 WEIGHT AND BALANCE DATA AND RECORD

The Basic Empty Weight, Center of Gravity Location and Useful Load listed in Figure 6-5 are for the airplane as licensed at the factory. These figures apply only to the specific airplane serial number and registration number shown.

The basic empty weight of the airplane as licensed at the factory has been entered in the Weight and Balance Record (Figure 6-7). This form is provided to present the current status of the airplane basic empty weight and a complete history of previous modifications. Any change to the permanently installed equipment or modification which affects weight or moment must be entered in the Weight and Balance Record and Equipment List.

MODEL PA-28-161, WARRIOR III

Airplane Serial Number _____

Registration Number _____

Date _____

AIRPLANE BASIC EMPTY WEIGHT

Item	Weight x (Lbs)	C.G. Arm (Inches Aft of Datum)	= Moment (In-Lbs)
	Actual		
Standard Empty Weight*	Computed		
Optional Equipment			
Basic Empty Weight			

*The standard empty weight includes full oil capacity and 2.0 gallons of unusable fuel.

AIRPLANE USEFUL LOAD — NORMAL CATEGORY OPERATION

(Ramp Weight) - (Basic Empty Weight) = Useful Load

(Normal Category: (2447 lbs) - (lbs) = lbs

(Utility Category: (2027 lbs) - (lbs) = lbs

THIS BASIC EMPTY WEIGHT, C.G., AND USEFUL LOAD ARE FOR THE AIRPLANE AS LICENSED AT THE FACTORY. REFER TO APPROPRIATE AIRCRAFT RECORD WHEN ALTERATIONS HAVE BEEN MADE.

WEIGHT AND BALANCE DATA FORM

Figure 6-5

**SECTION 6
WEIGHT AND BALANCE**

**PIPER AIRCRAFT CORPORATION
PA-28-161, WARRIOR III**

THIS PAGE INTENTIONALLY LEFT BLANK

PA-28-161	Serial Number		Registration Number	Page Number										
	Date	Item No.		Added (+) Removed (-)	Description of Article or Modification	Wt. (Lb.)	Arm (In.)	Moment /100	Running Basic Empty Weight	Wt. (Lb.)	Moment /100			

WEIGHT AND BALANCE RECORD

Figure 6-7

**SECTION 6
WEIGHT AND BALANCE**

**PIPER AIRCRAFT CORPORATION
PA-28-161, WARRIOR III**

PA-28-161	Serial Number		Registration Number			Page Number	
	Date	Item No.	Description of Article or Modification	Added (+) Removed (-)	Wt. (Lb.)	Arm (In.)	Moment /100
		Weight Change		Running Basic Empty Weight	Wt. (Lb.)	Moment /100	

WEIGHT AND BALANCE RECORD (cont)

Figure 6-7 (cont)

6.7 WEIGHT AND BALANCE DETERMINATION FOR FLIGHT

- (a) Add the weight of all items to be loaded to the basic empty weight.
- (b) Use the Loading Graph (Figure 6-13) to determine the moment of all items to be carried in the airplane.
- (c) Add the moment of all items to be loaded to the basic empty weight moment.
- (d) Divide the total moment by the total weight to determine the C.G. location.
- (e) By using the figures of item (a) and item (d) (above), locate a point on the C.G. range and weight graph (Figure 6-15). If the point falls within the C.G. envelope, the loading meets the weight and balance requirements.

	Weight (Lbs)	Arm Aft Datum (Inches)	Moment (In-Lbs)
Basic Empty Weight	1500.0	85.9	128850
Pilot and Front Passenger	340.0	80.5	27370
Passengers (Rear Seats)*	340.0	118.1	40154
Fuel (48 Gallon Maximum)	267.0	95.0	25365
Baggage* (200 Lbs. Maximum)		142.8	
Ramp Weight (2447 Lbs. Normal, 2027 Lbs. Utility Maximum)	2447.0	90.6	221739
Fuel Allowance For Engine Start, Taxi and Run Up	-7.0	95.0	-665
Takeoff Weight (2440 Lbs. Normal, 2020 Lbs. Utility Maximum)	2440.0	90.6	221074

The center of gravity (C.G.) of this sample loading problem is at 90.6 inches aft of the datum line. Locate this point (90.6) on the C.G. range and weight graph. Since this point falls within the weight - C.G. envelope, this loading meets the weight and balance requirements.

IT IS THE RESPONSIBILITY OF THE PILOT AND AIRCRAFT OWNER TO INSURE THAT THE AIRPLANE IS LOADED PROPERLY.

*Utility Category Operation - No baggage or aft passengers allowed.

SAMPLE LOADING PROBLEM (NORMAL CATEGORY)

Figure 6-9

**SECTION 6
WEIGHT AND BALANCE**

**PIPER AIRCRAFT CORPORATION
PA-28-161, WARRIOR III**

	Weight (Lbs)	Arm Aft Datum (Inches)	Moment (In-Lbs)
Basic Empty Weight			
Pilot and Front Passenger		80.5	
Passengers (Rear Seats)*		118.1	
Fuel (48 Gallon Maximum)		95.0	
Baggage* (200 Lbs. Maximum)		142.8	
Ramp Weight (2447 Lbs. Normal, 2027 Lbs. Utility Maximum)			
Fuel Allowance For Engine Start, Taxi and Run Up	-7	95.0	-665
Takeoff Weight (2440 Lbs. Normal, 2020 Lbs. Utility Maximum)			

Totals must be within approved weight and C.G. limits. It is the responsibility of the airplane owner and the pilot to insure that the airplane is loaded properly. The Basic Empty Weight C.G. is noted on the Weight and Balance Data Form (Figure 6-5). If the airplane has been altered, refer to the Weight and Balance Record for this information.

*Utility Category Operation - No baggage or aft passengers allowed.

WEIGHT AND BALANCE LOADING FORM

Figure 6-11

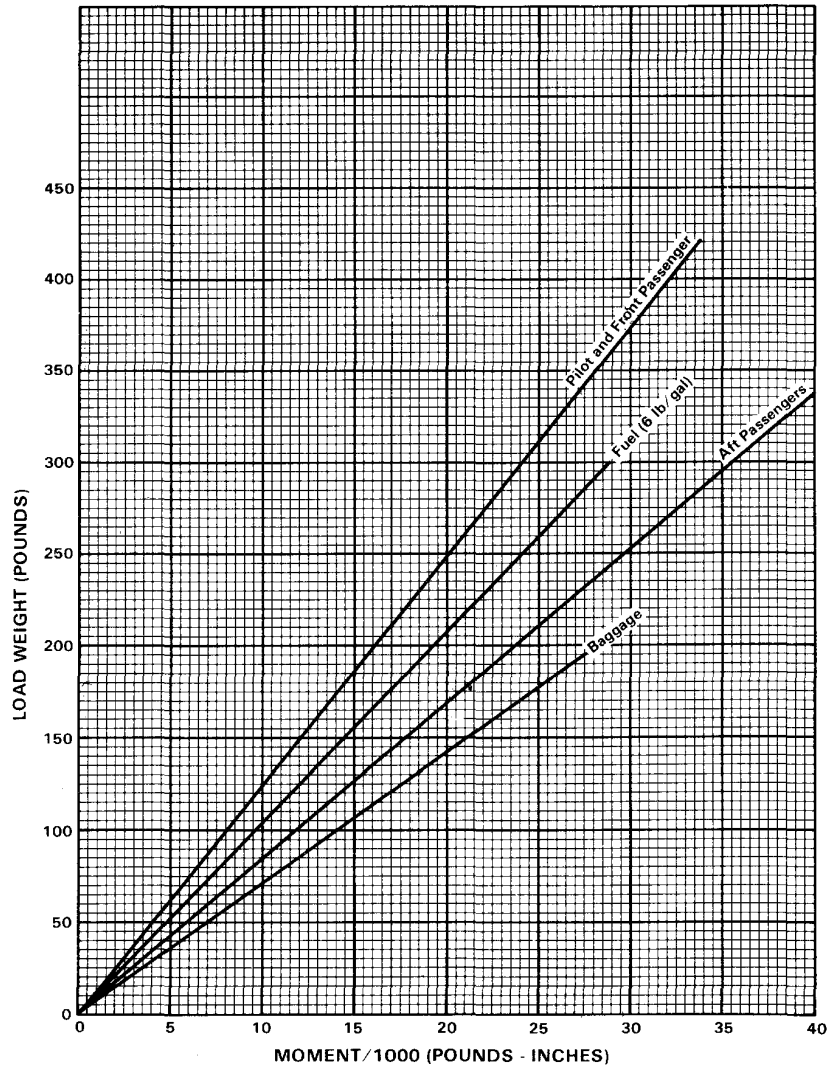

LOADING GRAPH
Figure 6-13

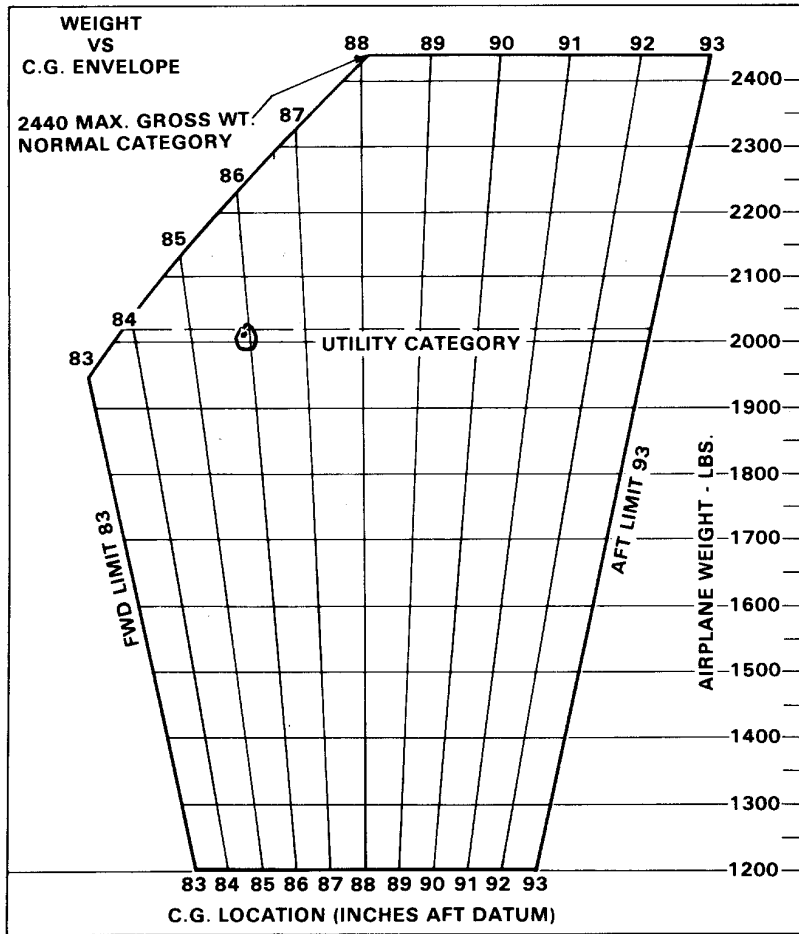

C.G. RANGE AND WEIGHT

Figure 6-15

TABLE OF CONTENTS
SECTION 7
DESCRIPTION AND OPERATION
OF THE AIRPLANE AND ITS SYSTEMS

Paragraph No.		Page No.
7.1	The Airplane.....	7-1
7.3	Airframe	7-1
7.5	Engine and Propeller	7-2
7.7	Landing Gear	7-4
7.9	Flight Controls.....	7-5
7.11	Engine Controls.....	7-6
7.13	Fuel System	7-8
7.15	Electrical System.....	7-10
7.17	Vacuum System	7-13
7.19	Instrument Panel.....	7-15
7.21	Pitot-Static System	7-18
7.23	Heating and Ventilating System	7-21
7.25	Cabin Features.....	7-21
7.27	Baggage Area	7-22
7.29	Stall Warning	7-22
7.31	Finish	7-22
7.33	Piper External Power.....	7-23
7.35	Emergency Locator Transmitter	7-23
7.37	Air Conditioning	7-25
7.39	Carburetor Ice Detection System	7-26

THIS PAGE INTENTIONALLY LEFT BLANK

REPORT: VB-1565

7-ii

SECTION 7

DESCRIPTION AND OPERATION OF THE AIRPLANE AND ITS SYSTEMS

7.1 THE AIRPLANE

The WARRIOR III is a single-engine, fixed gear monoplane of all metal construction with low semi-tapered wings. It has four place seating and a baggage capacity of two hundred pounds.

7.3 AIRFRAME

The primary structure, with the exception of the steel tube engine mount, steel landing gear struts and isolated areas, is of aluminum alloy construction. Lightweight plastics are used extensively in the extremities - the wing tips, the engine cowling, etc. - and in nonstructural components throughout the airplane.

The fuselage is a conventional semi-monocoque structure. On the right side of the airplane is a cabin door for entrance and exit. A baggage door is installed aft of the rear seat.

The wing is of a conventional, semi-tapered design incorporating a laminar flow, NACA 652415, airfoil section. The cantilever wings are attached to each side of the fuselage by insertion of the butt ends of the main spars into a spar box carry-through which is an integral part of the fuselage structure. The spar box carry-through structure, located under the rear seat, provides in effect a continuous main spar. The wings are also attached fore and aft of the main spar by an auxiliary front spar and a rear spar. The rear spar, in addition to taking torque and drag loads, provides a mount for flaps and ailerons. The four-position wing flaps are mechanically controlled by a handle located between the front seats. When fully retracted, the right flap locks into place to provide a step for cabin entry. Each wing contains one fuel tank.

A vertical stabilizer, an all-movable horizontal stabilator, and a rudder make up the empennage. The stabilator incorporates an anti-servo tab which improves longitudinal stability and provides longitudinal trim. This tab moves in the same direction as the stabilator, but with increased travel.

7.5 ENGINE AND PROPELLER

The PA-28-161 is powered by a four cylinder, direct drive, horizontally opposed engine rated at 160 HP at 2700 RPM. It is equipped with a starter, a 60 amp 28 volt alternator, a shielded ignition, two magnetos, vacuum pump drive, a fuel pump, and a wetted polyurethane foam induction air filter.

The engine compartment is accessible for inspection through top-hinged side panels on either side of the engine cowlings. The engine cowlings are cantilever structures attached at the fire wall. The engine mounts are constructed of steel tubing, and dynafocal mounts are provided to reduce vibration.

The exhaust system is constructed of stainless steel and incorporates dual mufflers with heater shrouds to supply heated air for the cabin, the defroster system and the carburetor deicing system.

An oil cooler is located on the left rear of the engine mounted to the engine baffling. Engine cooling air, which is picked up in the nose section of the engine cowling and carried through the baffling, is utilized on the left side for the oil cooler. A winterization plate is provided to restrict air during winter operation (refer to Section 8).

Engine air enters on either side of the propeller through openings in a nose cowling and is carried through the engine baffling around the engine and oil cooler. Air for the muffler shroud is also picked up from the nose cowling and carried through a duct to the shroud. Carburetor induction air enters a chin scoop on the lower right cowling and is passed through a wetted polyurethane filter to the carburetor air box. Heated air enters the carburetor air box through a hose connected to the heater shroud.

A fixed pitch propeller is installed as standard equipment. The propeller has a 74-inch diameter with a 60-inch pitch. The pitch is determined at 75% of the diameter. The propeller is made of an aluminum alloy construction.

The pilot should read and follow the procedures recommended in the Lycoming Operator's Manual for this engine in order to obtain maximum engine efficiency and time between engine overhauls.

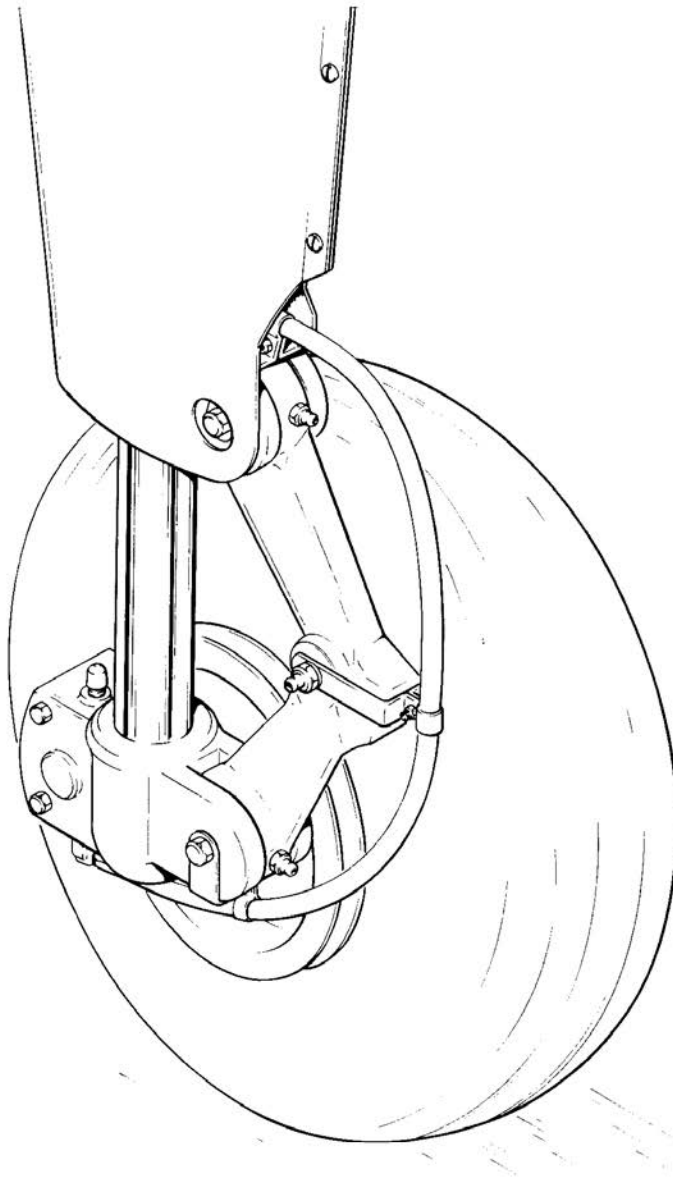

MAIN WHEEL ASSEMBLY
Figure 7-1

7.7 LANDING GEAR

The fixed-gear PA-28-161 is equipped with a Cleveland 5.00 x 5 wheel on the nose gear and a Cleveland 6.00 x 6 wheel on each main gear (Figure 7-1). Cleveland single disc hydraulic brake assemblies are provided on the main gear. The nose gear has a 5.00 x 5 four-ply tire, while the main wheel assemblies have 6.00 x 6 four-ply tires. At gross weight, the main gear tires require a pressure of 24 psi, and the nose gear tire requires a pressure of 30 psi.

A spring device is incorporated in the rudder pedal torque tube assembly to provide rudder trim. A bungee in the nose gear steering mechanism reduces steering effort and dampens bumps and shocks during taxiing. By using the rudder pedals and the brakes, the nose gear is steerable through a 30 degree arc each side of center. Later aircraft have the bungee removed from the nose gear steering mechanism and are steerable through a 20 degree arc each side of center. A shimmy dampener is also included in the nose gear.

The three struts are of the air-oil type with the normal static load extension being 3.25 inches for the nose gear and 4.50 inches for the main gear.

The brakes are actuated by toe brake pedals which are attached to the rudder pedals or by a hand lever and master cylinder located below and behind the center of the instrument sub panel. Hydraulic cylinders are located above each pedal and adjacent to the hand brake lever. The brake fluid reservoir is installed on the top left front face of the fire wall. The parking brake is incorporated in the master cylinder and is actuated by pulling back on the brake lever and depressing the knob attached to the left side of the handle. To release the parking brake, pull back on the brake lever to disengage the catch mechanism and allow the handle to swing forward (refer to Figure 7-5).

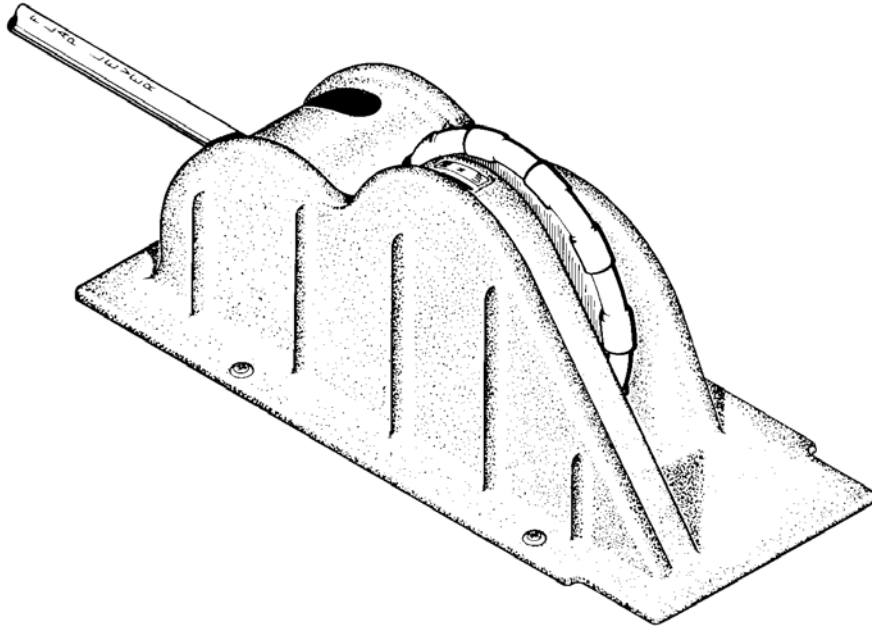

FLIGHT CONTROL CONSOLE

Figure 7-3

7.9 FLIGHT CONTROLS

Dual flight controls are provided as standard equipment. The flight controls actuate the control surfaces through a cable system.

The horizontal surface (stabilator) is of the flying tail design with a trim tab mounted on the trailing edge. This tab serves the dual function of providing trim control and pitch control forces. The trim tab is actuated by a trim control wheel located on the control console between the front seats (Figure 7-3). Forward rotation of the wheel gives nose down trim and aft rotation gives nose up trim.

The rudder is conventional in design and incorporates a rudder trim. The trim mechanism is a spring loaded recentering device. The trim control is located on the right side of the pedestal below the throttle quadrant (refer to Figure 7-5). Turning the trim control clockwise gives nose right trim and counterclockwise rotation gives nose left trim.

Manually controlled flaps are provided on the PA-28-161. The flaps are balanced and spring loaded to return to the retracted (up) position. A control handle, which is located between the two front seats on the control console (Figure 7-3), extends the flaps by the use of a control cable. To extend the flaps, the handle is pulled up to the desired flap setting of 10, 25 or 40 degrees. To retract, depress the button on the end of the handle and lower the control. When extending or retracting flaps, there is a pitch change in the airplane. This pitch change can be corrected either by stabilator trim or increased control wheel force. When the flaps are in the retracted (up) position the right flap, provided with an over-center lock mechanism, acts as a step.

NOTE

The right flap will support a load only in the fully retracted (up) position. When the flap is to be used as a step, make sure the flaps are in the retracted (up) position.

7.11 ENGINE CONTROLS

Engine controls consist of a throttle control and a mixture control lever. These controls are located on the control quadrant on the lower center of the instrument panel (Figure 7-5) where they are accessible to both the pilot and the copilot. The controls utilize teflon-lined control cables to reduce friction and binding.

The throttle lever is used to adjust engine RPM. The mixture control lever is used to adjust the air to fuel ratio. The engine is shut down by the placing of the mixture lever in the full lean position. For information on the leaning procedure, see the Avco-Lycoming Operator's Manual.

The friction adjustment lever on the right side of the control quadrant may be adjusted to increase or decrease the friction holding the throttle and mixture controls or to lock the controls in a selected position.

The carburetor heat control lever is located to the right of the control quadrant on the instrument panel. The control is placarded with two positions: ON (down), OFF (up).

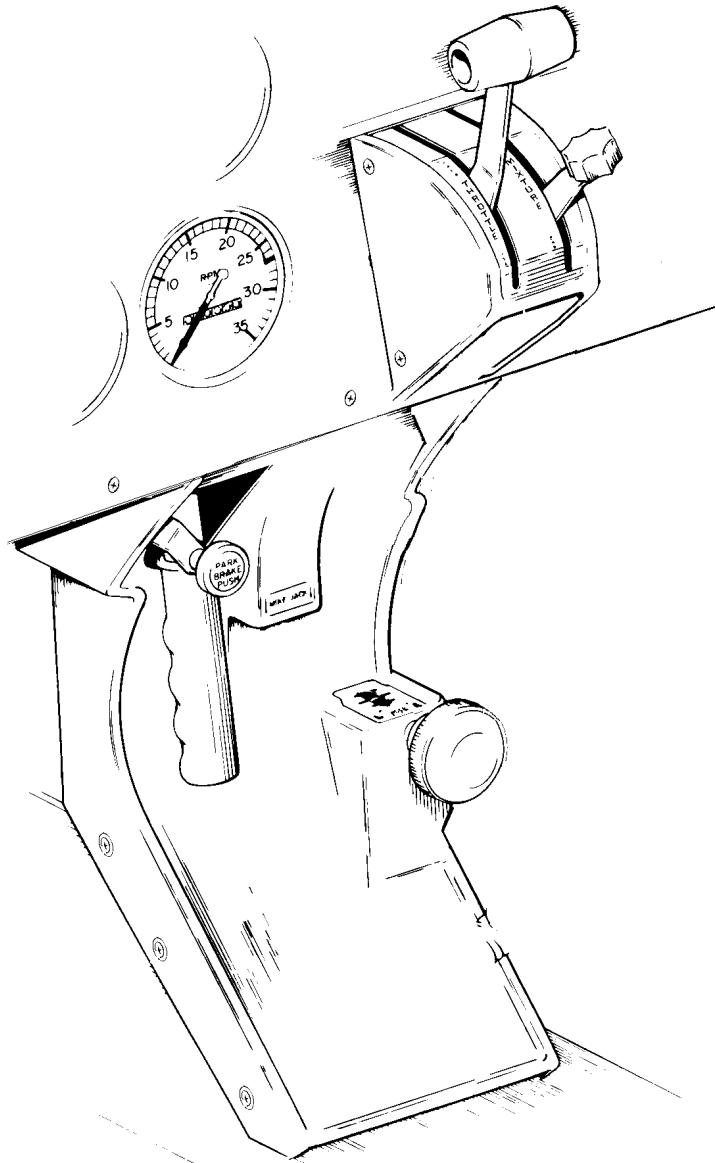

CONTROL QUADRANT AND CONSOLE

Figure 7-5

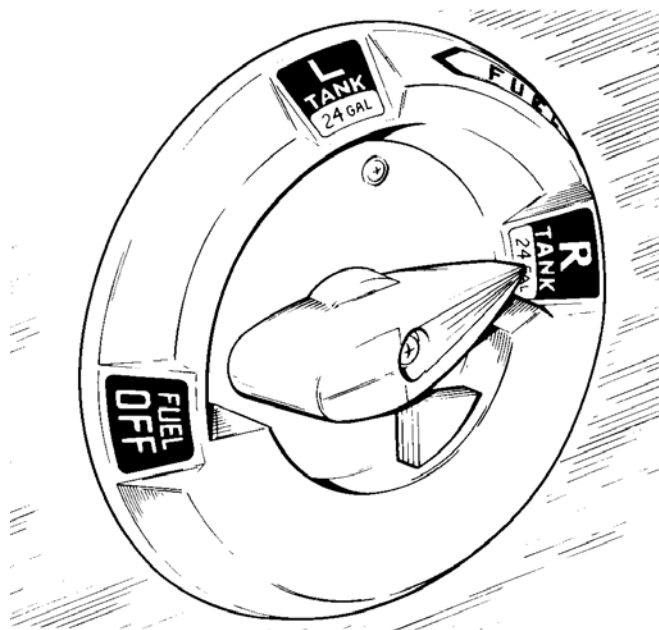

FUEL SELECTOR

Figure 7-7

7.13 FUEL SYSTEM

Fuel is stored in two twenty-five gallon (24 gallons usable) fuel tanks, giving the airplane a total capacity of fifty U.S. gallons (48 gallons usable). Each tank is equipped with a filler neck indicator tab to aid in determining fuel remaining when the tanks are not full. Usable capacity to the bottom of the indicator tab is 17 gallons. The tanks are secured to the leading edge of each wing with screws and nut plates. This allows removal for service or inspection.

The fuel tank selector control (Figure 7-7) is located on the left side panel forward of the pilot's seat. The button on the selector cover must be depressed and held while the handle is moved to the OFF position. The button releases automatically when the handle is moved back to the ON position.

An auxiliary electric fuel pump is provided in case of the failure of the engine-driven pump. The electric pump should be ON for all takeoffs and landings and when switching tanks. The fuel pump switch is located in the switch panel above the throttle quadrant.

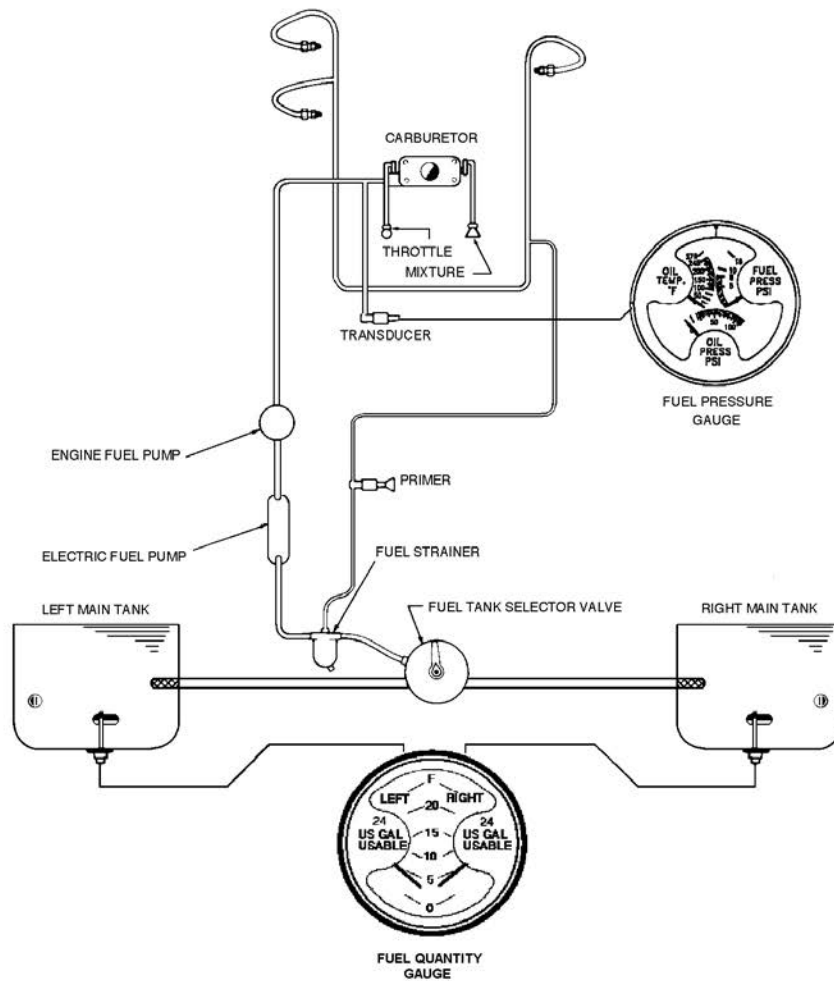

FUEL SYSTEM SCHEMATIC

Figure 7-9

The fuel drains should be opened daily prior to first flight to check for water or sediment and proper fuel. Each tank has an individual drain at the bottom, inboard rear corner. A fuel strainer, located on the lower left front of the fire wall, has a drain which is accessible from outside the nose section. The strainer should also be drained before the first flight of the day. Refer to Section 8 for the complete fuel draining procedure.

Fuel quantity and fuel pressure gauges are combined in a single gauge located on the center of the instrument panel just above the engine tachometer (refer to Figure 7-15).

An electric engine priming system is available to facilitate starting. Pressing the momentary primer switch on, automatically activates the electric fuel pump and opens a solenoid valve, which then supplies fuel to the fuel primer lines.

7.15 ELECTRICAL SYSTEM

The electrical system includes a 28-volt, 60-amp alternator; a 24-volt battery; a voltage regulator and a master switch relay (Figure 7-11). The battery is in a box, mounted on the forward right face of the fire wall. The regulator and overvoltage relay are located on the forward left side of the fuselage behind the instrument panel.

Electrical switches are located on the right center instrument panel (refer to Figure 7-15), and the circuit breakers are located on the lower right instrument panel (refer to Figure 7-13). Three rheostat switches located on the pilots lower instrument panel controls and dims the switch, panel and avionics lights.

Standard electrical accessories include a starter, electric fuel pump, stall warning indicator, fuel gauge, ammeter, and annunciator panel.

The annunciator panel includes alternator inop., and oil pressure indicator lights. The annunciator panel also includes a vacuum inop. light, low volts and starter engage indicator lights. The annunciator panel lights are provided only as a warning to the pilot that a system may not be operating properly, and that he should check and monitor the applicable system gauge to determine when or if any necessary action is required.

Electrical accessories include navigation lights, wing tip recognition lights, wing tip strobe lights, landing light, instrument lighting, and cabin dome light. Circuits will handle the addition of communications and navigational equipment.

A flood light, mounted in the overhead panel, provides instrument and cockpit lighting for night flying. The light is controlled by a rheostat switch located adjacent to the light. A map light window in the lens is actuated by an adjacent switch.

WARNING

Anti-collision lights should not be operating when flying through cloud, fog or haze, since the reflected light can produce spatial disorientation. Strobe lights should not be used in close proximity to the ground such as during taxiing, takeoff or landing.

Unlike previous generator systems, the ammeter as installed does not show battery discharge; rather, it indicates the electrical load on the alternator in amperes. With all the electrical equipment off and the master switch on, the ammeter will indicate the charging rate of the battery. As each electrical unit is switched on, the ammeter will indicate the total ampere draw of all the units including the battery. For example, the average continuous load for night flight with radios on is about 30 amperes. This 30 ampere value plus approximately 2 amperes for a fully charged battery will appear continuously under these flight conditions. The amount of current shown on the ammeter will tell immediately if the alternator system is operating normally, as the amount of current shown should equal the total amperage drawn by the electrical equipment which is operating.

For abnormal and/or emergency operation and procedures, see Section 3.

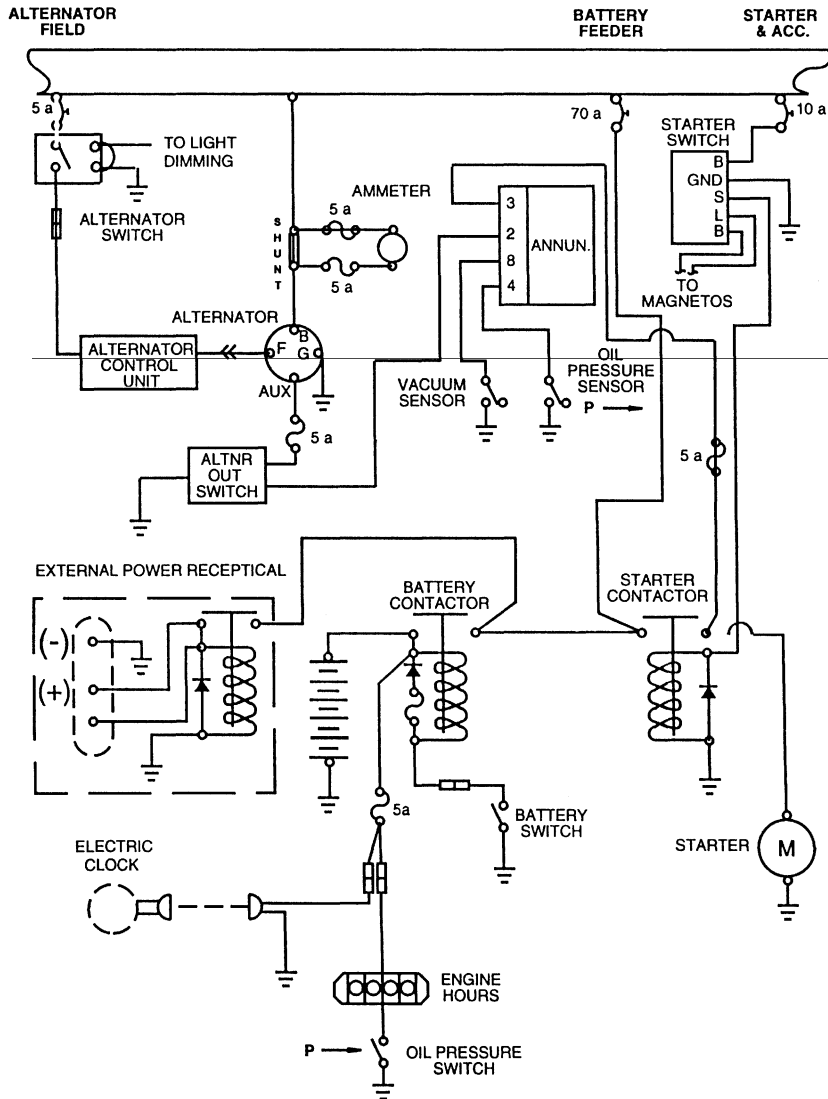

ALTERNATOR AND STARTER SCHEMATIC

Figure 7-11

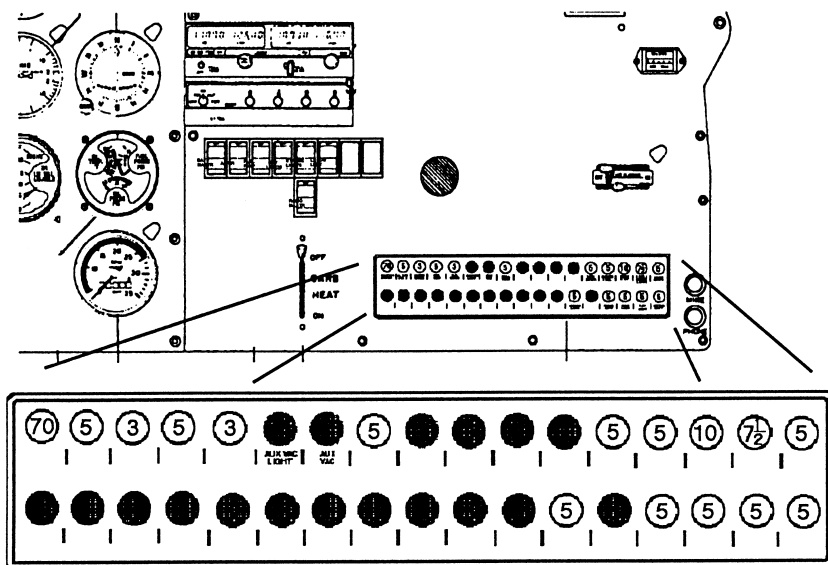

CIRCUIT BREAKER PANEL

Figure 7-13

7.17 VACUUM SYSTEM

The vacuum system is designed to operate the air-driven gyro instruments. This includes the directional and attitude gyros when installed. The system consists of an engine driven vacuum pump, a vacuum regulator, a filter and the necessary plumbing.

The vacuum pump is a dry-type pump. A shear drive protects the pump from damage. If the drive shears, the gyros will become inoperative.

A vacuum gauge, mounted on the far left instrument panel, provides a pilot check for the system during operation. A decrease in pressure in a system that remained constant over an extended period may indicate a dirty filter, dirty screens, possibly a sticky vacuum regulator or leak in the system (a low vacuum indicator light is provided in the annunciator panel). Zero pressure would indicate a sheared pump drive, defective pump, possibly a defective

**SECTION 7
DESCRIPTION & OPERATION**

**PIPER AIRCRAFT CORPORATION
PA-28-161, WARRIOR III**

gauge or collapsed line. In the event of any gauge variation from the norm, the pilot should have a mechanic check the system to prevent possible damage to the system components or eventual failure of the system.

A vacuum regulator is provided in the system to protect the gyros. The valve is set so the normal vacuum reads 4.8 to 5.2 inches of mercury, a setting which provides sufficient vacuum to operate all the gyros at their rated RPM. Higher settings will damage the gyros and with a low setting the gyros will be unreliable. The regulator is located behind the instrument panel. Vacuum pressure, even though set correctly, can read lower at very high altitude (above 12,000 ft), and at low engine RPM (usually on approach or during training maneuvers). This is normal and should not be considered a malfunction.

7.19 INSTRUMENT PANEL

The instrument panel (Figure 7-15) is designed to accommodate instruments and avionics equipment for VFR and IFR flights.

The artificial horizon and directional gyro are vacuum operated and are located in the center of the left hand instrument panel. The vacuum gauge is located on the upper left hand instrument panel. The turn indicator on the left side is electrically operated.

The radios are located in the center section of the panel, and the circuit breakers are in the lower right corner of the panel.

Standard instruments include a compass, an airspeed indicator, a tachometer, altimeter, ammeter, engine cluster gauge, fuel quantity gauge, and an annunciator panel. The compass is mounted on the windshield bow in clear view of the pilot.

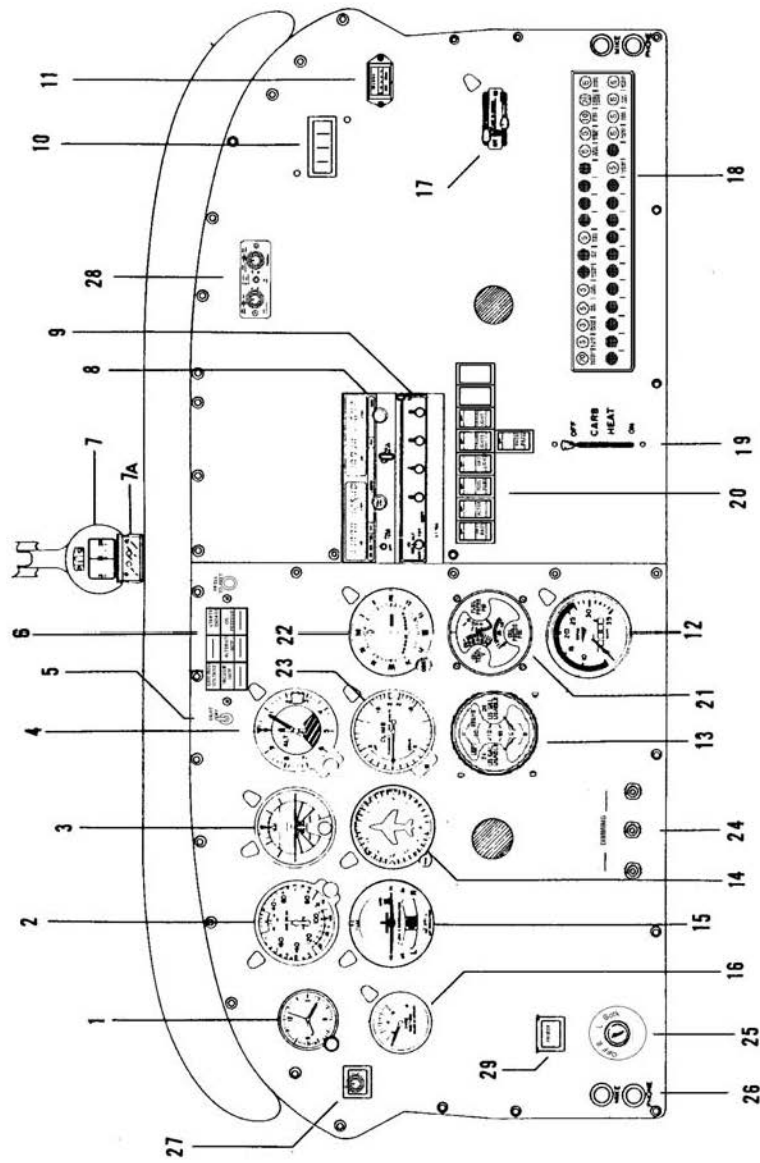

TYPICAL INSTRUMENT PANEL

Figure 7-15

- | | |
|--------------------------------|----------------------------------|
| 1. CLOCK (ELECTRIC) (OPTIONAL) | 17. CABIN AIR CONTROL |
| 2. AIRSPEED INDICATOR | WINDSHIELD DEFROST AND HEAT |
| 3. ATTITUDE GYRO | 18. CIRCUIT BREAKER PANEL |
| 4. ALTIMETER | 19. CARB. HEAT |
| 5. DAY/NIGHT SWITCH | 20. SWITCH PANEL |
| 6. ANNUNCIATOR PANEL | 21. ENGINE GAUGE, OIL TEMP |
| 7. COMPASS (MAGNETIC) | OIL AND FUEL PRESSURE |
| 7a. COMPASS CORRECTION CARD | 22. VOR/LOC NAVIGATION INDICATOR |
| 8. COMM / NAV RADIO | 23. VERTICAL SPEED INDICATOR |
| 9. TRANSPONDER | 24. LIGHT CONTROL AND DIMMING |
| 10. AMMETER (DIGITAL) | SWITCH, INST. PANEL, & RADIOS |
| 11. HOUR METER | 25. MAGNETO & START SWITCH |
| 12. TACHOMETER (RPM) | 26. MIC/PHONE JACKS |
| 13. FUEL QUANTITY | 27. ELT CONTROL |
| 14. DIRECTIONAL GYRO | 28. INTERCOM CONTROL |
| 15. TURN & BANK | 29. ENGINE PRIMER (ELECTRIC) |
| 16. VACUUM GAUGE | |

TYPICAL INSTRUMENT PANEL

Figure 7-15 (cont)

7.21 PITOT-STATIC SYSTEM

The system supplies both pitot and static pressure for the airspeed indicator, altimeter, and vertical speed indicator (Figure 7-17).

Pitot and static pressure are picked up by a pitot head installed on the bottom of the left wing and carried through pitot and static lines within the wing and fuselage to the gauges on the instrument panel.

An alternate static source control valve is located below the left side of the instrument panel. When the valve is set in the alternate position, the altimeter, vertical speed indicator and airspeed indicator will be using cabin air for static pressure. The storm window and cabin vents must be closed and the cabin heater and defroster must be on during alternate static source operation. The altimeter error is less than 50 feet unless otherwise placarded.

Both the pitot and static lines can be drained through separate drain valves located on the left lower side of the fuselage interior.

A heated pitot head, which alleviates problems with icing and heavy rain, is available as optional equipment. The switch for the heated pitot head is located on the electrical switch panel to the left of the right control wheel.

A pitot heat inop/off annunciator is provided with the heated pitot head option. The annunciator will be on anytime the pitot heat is turned off or is drawing insufficient current to adequately heat the pitot head.

To prevent bugs and water from entering the pitot and static pressure holes, a cover should be placed over the pitot head. A partially or completely blocked pitot head will give erratic or zero readings on the instruments.

NOTE

During the preflight, check to make sure the pitot cover is removed.

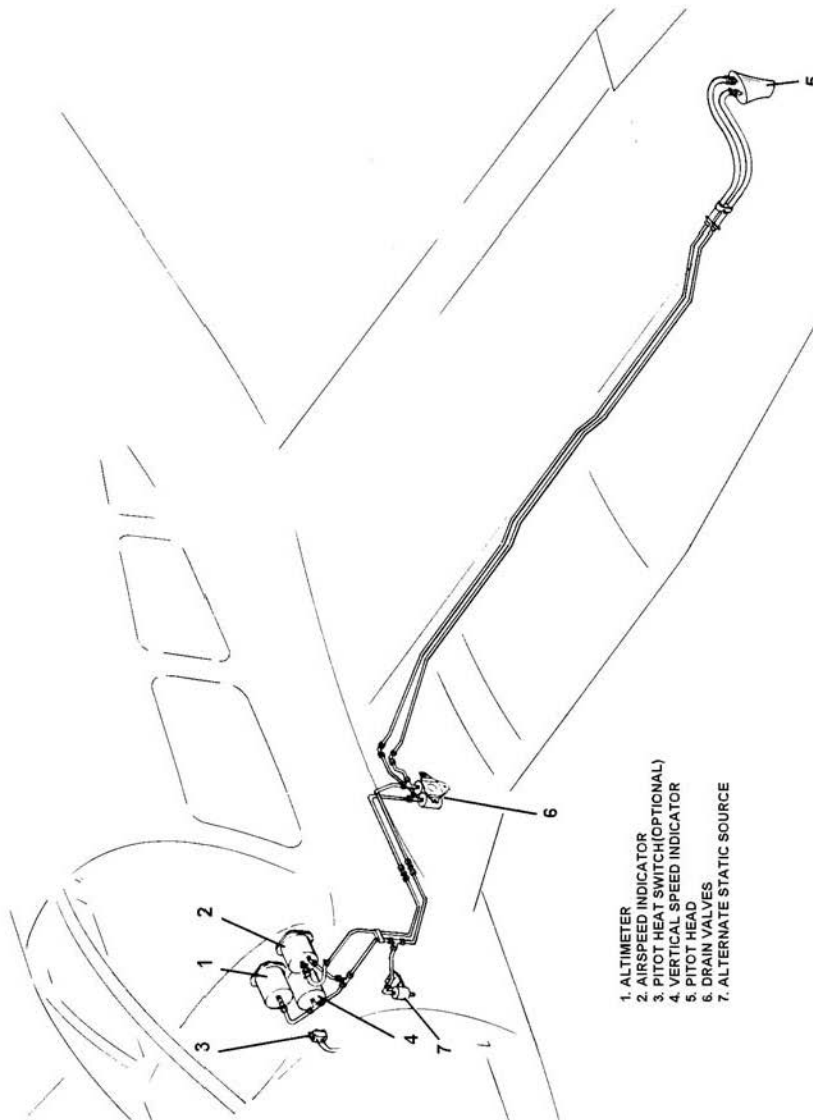

PITOT-STATIC SYSTEM

Figure 7-17

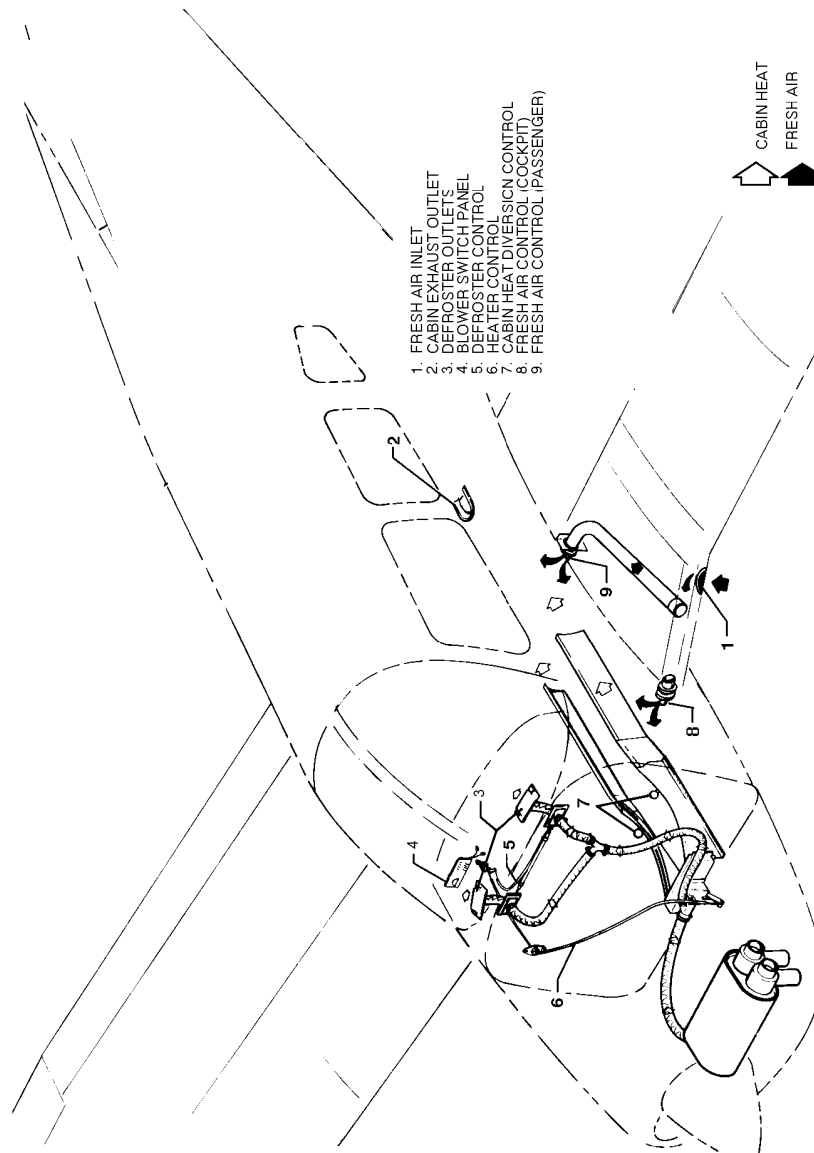

HEATING AND VENTILATING SYSTEM

Figure 7-19

7.23 HEATING AND VENTILATING SYSTEM

Heat for the cabin interior and the defroster system is provided by a shroud attached to the muffler (Figure 7-19). The amount of heat can be regulated with the controls located on the far right side of the instrument panel.

The airflow between front and rear seats can be regulated by the heat diversion controls located on either side of the console atop the heat ducts.

CAUTION

When cabin heat is operated, heat duct surface becomes hot. This could result in burns if arms or legs are placed too close to heat duct outlets or surface.

Fresh air inlets are located in the leading edges of the wings near the fuselage. At each front seat location there is an adjustable fresh air outlet on the side of the cabin near the floor. Cabin air is exhausted through an outlet located below the rear seat.

7.25 CABIN FEATURES

For ease of entry and exit and for pilot-passenger comfort, the front seats are adjustable fore and aft. The right front seat tilts forward to allow easy entry to the rear seats. The cabin interior includes a pilot storm window, ash trays and armrests on each front seat, two map pockets and pockets on the backs of the front seats.

The front seats are vertically adjustable.

Shoulder harnesses with inertia reels are provided for each front seat occupant and, depending on the model year, are provided as standard or optional equipment for the occupants of the rear seats. A check of the inertia reel mechanism can be made by pulling sharply on the strap and checking that the reel will lock in place under sudden stress. This locking feature prevents the strap from extending and holds the occupant in place. Under normal movement the strap will extend and retract as required. Shoulder harnesses should be routinely worn during takeoff, landing and whenever an inflight emergency situation occurs.

7.27 BAGGAGE AREA

A 24 cubic foot baggage area, located behind the rear seat, is accessible from the cabin or loaded through a large 20 x 22 inch outside baggage door on the right side of the fuselage. Maximum capacity is 200 pounds. Tie-down straps are available and they should be used at all times.

NOTE

It is the pilot's responsibility to be sure when the baggage is loaded that the aircraft C.G. falls within the allowable C.G. range. (See Weight and Balance Section.)

7.29 STALL WARNING

An approaching stall is indicated by an audible alarm located behind the instrument panel. The indicator activates at between five and ten knots above stall speed.

7.31 FINISH

All exterior surfaces are primed with etching primer and finished with acrylic lacquer. To keep the finish attractive, economy size spray cans of touch-up paint are available from Piper Dealers.

7.33 PIPER EXTERNAL POWER

A external power receptacle is accessible through a receptacle cover door located on the right rear side of the fuselage, aft of the wing. An external battery can be connected to the socket, thus allowing the operator to crank the engine without having to gain access to the airplane's battery. Instructions on a placard located on the cover door of the receptacle should be followed before using the external power. For instructions see *STARTING WITH EXTERNAL POWER SOURCE* in Section 4 - Normal Operating Procedures.

7.35 EMERGENCY LOCATOR TRANSMITTER*

The Emergency Locator Transmitter (ELT), when installed, is located in the aft portion of the fuselage just below the stabilator leading edge and is accessible through a plate on the right side of the fuselage. This plate is attached with slotted-head nylon screws for ease of removal; these screws may be readily removed with a variety of common items such as a dime, a key, a knife blade, etc. If there are no tools available in an emergency, the screw heads may be broken off by any means. The ELT meets the requirements of FAR 91.52.

A battery replacement date is marked on the transmitter to comply with FAA regulations, the battery must be replaced on or before this date. The battery must also be replaced if the transmitter has been used in an emergency situation or, if the accumulated test time exceeds one hour, or if the unit has been inadvertently activated for an undetermined time period.

NOTE

If for any reason a test transmission is necessary, the test transmission should be conducted only in the first five minutes of any hour and limited to three audio sweeps. If the tests must be made at any other time, the tests should be coordinated with the nearest FAA tower or flight service station.

ARTEX 110-4 ELT OPERATION

On the ELT unit itself is a two position switch placarded ON and OFF. The OFF position is selected when the transmitter is installed at the factory and the switch should remain in that position whenever the unit is installed in the airplane.

A pilots remote switch, placarded ON and ARM is located on the left hand side of the pilot's instrument panel to allow the transmitter to be armed or turned on from inside the cabin. The switch is normally in ARM position. Moving the switch to ON will activate the transmitter. A warning light located above the remote switch will alert you when ever the ELT is activated.

Should the ELT be activated inadvertently it can be reset by either positioning the remote switch to the ON then immediately relocating it to the ARM position, or by setting the switch on the ELT to ON and then back to OFF.

In the event the transmitter is activated by an impact, it can be turned off by moving the ELT switch OFF. Normal operation can then be restored by resetting the switch to ARM. It may also be turned off and reset by positioning the remote switch to the ON and then immediately to the ARM position.

The transmitter can be activated manually at any time by placing either the remote switch or the ELT switch to the ON position.

NOTE:

Three sweeps of the emergency tone and an illuminated warning light indicates a normally functioning unit. The warning light must illuminate during the first 3 second test period. If it does not illuminate, a problem is indicated such as a "G" switch failure.

The ELT should be checked during postflight to make certain the unit has not been activated. Check by selecting 121.50 MHz on an operating receiver. If a downward sweeping audio tone is heard the ELT may have been activated. Set the remote switch to ON. If there is no change in the volume of the signal, your airplane's ELT is probably transmitting. Setting the remote switch back to OFF will automatically reset the ELT and should stop the signal being received on 121.50 MHz.

TABLE OF CONTENTS
SECTION 8
AIRPLANE HANDLING, SERVICING AND MAINTENANCE

Paragraph No.		Page No.
8.1	General	8-1
8.3	Airplane Inspection Periods	8-2
8.5	Preventive Maintenance	8-3
8.7	Airplane Alterations	8-4
8.9	Ground Handling	8-5
8.11	Engine Air Filter.....	8-7
8.13	Brake Service	8-8
8.15	Landing Gear Service.....	8-9
8.17	Propeller Service	8-11
8.19	Oil Requirements.....	8-12
8.21	Fuel System	8-12
8.23	Tire Inflation.....	8-15
8.25	Battery Service	8-16
8.27	Cleaning	8-16
8.29	Cold Weather Operation.....	8-19

THIS PAGE INTENTIONALLY LEFT BLANK

REPORT: VB-1565
8-ii

SECTION 8

AIRPLANE HANDLING, SERVICING AND MAINTENANCE

8.1 GENERAL

This section provides general guidelines relating to the handling, servicing, and maintenance of the WARRIOR III. For complete maintenance instructions, refer to the PA-28-161 Maintenance Manual.

Every owner should stay in close contact with an authorized Piper Service Center or Piper's Customer Service Department to obtain the latest information pertaining to their airplane, and to avail themselves of Piper's support systems.

Piper takes a continuing interest in having owners get the most efficient use from their airplane and keeping it in the best mechanical condition. Consequently, Piper, from time to time, issues service releases including Service Bulletins, Service Letters, Service Spares Letters, and others relating to the airplane.

Piper Service Bulletins are of special importance and Piper considers compliance mandatory. These are available on the Piper.com website. Depending on the nature of the release, material and labor allowances may apply. This information is provided to all authorized Piper Service Centers.

Service Letters deal with product improvements and servicing techniques pertaining to the airplane. These are available on the Piper.com website.. Owners should give careful attention to Service Letter information.

Service Spares Letters offer improved parts, kits, and optional equipment which were not available originally, and which may be of interest to the owner.

Maintenance manuals, parts catalogs, and revisions to both, are available from Piper Service Centers.

Any correspondence regarding the airplane should include the airplane model and serial number to ensure proper response.

8.3 AIRPLANE INSPECTION PERIODS

Piper Aircraft Corporation has developed inspection items and required inspection intervals for the PA-28-161 (see the latest revision of the PA-28-161 Maintenance and Inspection Manuals). The PA-28-161 Inspection Manual contains appropriate forms, and all inspection procedures should be complied with by a properly trained, knowledgeable, and qualified mechanic at a Piper Authorized Service Center or a reputable repair shop. Piper Aircraft Corporation cannot accept responsibility for the continued airworthiness of any aircraft not maintained to these standards, and/or not brought into compliance with applicable Service Bulletins issued by Piper Aircraft Corporation, instructions issued by the engine, propeller, or accessory manufacturers, or Airworthiness Directives issued by the FAA.

A programmed inspection, approved by the FAA, is also available to the owner. This involves routine and detailed inspections to allow maximum utilization of the airplane. Maintenance inspection costs are reduced and the maximum standard of continued airworthiness is maintained. Complete details are available from Piper Aircraft Corporation.

In addition, but in conjunction with the above, the FAA requires periodic inspections on all aircraft to keep the Airworthiness Certificate in effect. The owner is responsible for assuring compliance with these inspection requirements and for maintaining proper documentation in logbooks and/or maintenance records.

A spectrographic analysis of the engine oil is available from several sources. This inspection, if performed properly, provides a good check of the internal condition of the engine. To be accurate, induction air filters must be cleaned or changed regularly, and oil samples must be taken and sent in at regular intervals.

8.5 PREVENTIVE MAINTENANCE

The holder of a pilot certificate issued under Federal Aviation Regulations (FAR) Part 61 may perform certain preventive maintenance as defined in the FARs. This maintenance may be performed only on an aircraft which the pilot owns and operates, and which is not used in air carrier or air taxi/commercial operations service.

All other aircraft maintenance must be accomplished by a person or facility appropriately certificated by the Federal Aviation Administration (FAA) to perform that work.

Anytime maintenance is accomplished, an entry must be made in the appropriate aircraft maintenance records. The entry shall include:

- (a) The date the work was accomplished.
- (b) Description of the work.
- (c) Number of hours on the aircraft.
- (d) The certificate number of pilot performing the work.
- (e) Signature of the individual doing the work.

8.7 AIRPLANE ALTERATIONS

If the owner desires to have his aircraft modified, he must obtain FAA approval for the alteration. Major alterations accomplished in accordance with Advisory Circular 43.13-2, when performed by an A & P mechanic, may be approved by the local FAA office. Major alterations to the basic airframe or systems not covered by AC 43.13-2 require a Supplemental Type Certificate.

The owner or pilot is required to ascertain that the following Aircraft Papers are in order and in the aircraft.

- (a) To be displayed in the aircraft at all times:
 - (1) Aircraft Airworthiness Certificate Form FAA-8100-2.
 - (2) Aircraft Registration Certificate Form FAA-8050-3.
 - (3) Aircraft Radio Station License if transmitters are installed.

- (b) To be carried in the aircraft at all times:
 - (1) Pilot's Operating Handbook.
 - (2) Weight and Balance data plus a copy of the latest Repair and Alteration Form FAA-337, if applicable.
 - (3) Aircraft equipment list.

Although the aircraft and engine logbooks are not required to be in the aircraft, they should be made available upon request. Logbooks should be complete and up to date. Good records will reduce maintenance cost by giving the mechanic information about what has or has not been accomplished.

8.9 GROUND HANDLING

(a) Towing

The airplane may be moved on the ground by the use of the nose wheel steering bar that is stowed below the forward ledge of the baggage compartment or by power equipment that will not damage or excessively strain the nose gear steering assembly. Towing lugs are incorporated as part of the nose gear fork.

CAUTIONS

When towing with power equipment, do not turn the nose gear beyond its steering radius in either direction, as this will result in damage to the nose gear and steering mechanism.

Do not tow the airplane when the controls are secured.

In the event towing lines are necessary, ropes should be attached to both main gear struts as high up on the tubes as possible. Lines should be long enough to clear the nose and/or tail by not less than fifteen feet, and a qualified person should ride in the pilot's seat to maintain control by use of the brakes.

(b) Taxiing

Before attempting to taxi the airplane, ground personnel should be instructed and approved by a qualified person authorized by the owner. Engine starting and shut-down procedures as well as taxi techniques should be covered. When it is ascertained that the propeller back blast and taxi areas are clear, power should be applied to start the taxi roll, and the following checks should be performed:

- (1) Taxi a few feet forward and apply the brakes to determine their effectiveness.
- (2) While taxiing, make slight turns to ascertain the effectiveness of the steering.
- (3) Observe wing clearance when taxiing near buildings or other stationary objects. If possible, station an observer outside the airplane.

- (4) When taxiing over uneven ground, avoid holes and ruts.
- (5) Do not operate the engine at high RPM when running up or taxiing over ground containing loose stones, gravel, or any loose material that may cause damage to the propeller blades.

(c) Parking

When parking the airplane, be sure that it is sufficiently protected from adverse weather conditions and that it presents no danger to other aircraft. When parking the airplane for any length of time or overnight, it is suggested that it be moored securely.

- (1) To park the airplane, head it into the wind if possible.
- (2) Set the parking brake by pulling back on the brake lever and depressing the knob on the handle. To release the parking brake, pull back on the handle until the catch disengages; then allow the handle to swing forward.

CAUTION

Care should be taken when setting brakes that are overheated or during cold weather when accumulated moisture may freeze a brake.

- (3) Aileron and stabilator controls should be secured with the front seat belt and chocks used to properly block the wheels.

(d) Mooring

The airplane should be moored for immovability, security and protection. The following procedures should be used for the proper mooring of the airplane:

- (1) Head the airplane into the wind if possible.
- (2) Retract the flaps.
- (3) Immobilize the ailerons and stabilator by looping the seat belt through the control wheel and pulling it snug.
- (4) Block the wheels.

- (5) Secure tie-down ropes to the wing tie-down rings and to the tail skid at approximately 45-degree angles to the ground. When using rope of non-synthetic material, leave sufficient slack to avoid damage to the airplane should the ropes contract.

CAUTION

Use bowline knots, square knots or locked slip knots. Do not use plain slip knots.

NOTE

Additional preparations for high winds include using tie-down ropes from the landing gear forks and securing the rudder.

- (6) Install a pitot head cover if available. Be sure to remove the pitot head cover before flight.
- (7) Cabin and baggage doors should be locked when the airplane is unattended.

8.11 ENGINE AIR FILTER

The wet-type polyurethane foam air filter must be inspected at least once every fifty hours. Under extremely adverse operating conditions, it may be necessary to inspect the filter more frequently. The filter is disposable and inexpensive and a spare should be kept on hand for a rapid replacement.

(a) Removal Of Engine Air Filter

The filter is located in the lower right front of the engine compartment and may be removed by the following procedure:

- (1) Open the right side of the engine cowling.
- (2) Loosen each of the four quarter-turn fasteners securing the air filter cover.
- (3) Separate the cover and remove the filter.
- (4) Inspect the filter. If it is excessively dirty or shows any damage, replace it immediately.

(b) Cleaning Engine Air Filter

The induction air filter must be cleaned at least once every 50 hours, and more often, even daily, when operating in dusty conditions. Extra filters are inexpensive, and a spare should be kept on hand for use as a rapid replacement.

To clean the filter:

- (1) Tap the filter gently to remove dirt particles, being careful not to damage the filter. DO NOT wash the filter in any liquid. DO NOT attempt to blow out dirt with compressed air.
- (2) If the filter is excessively dirty or shows any damage, replace it immediately.
- (3) Wipe the filter housing with a clean cloth soaked in unleaded gasoline. When the filter housing is clean and dry, install the filter.

(c) Installation Of Engine Air Filter

When replacing the filter, install the filter in the reverse order of removal.

8.13 BRAKE SERVICE

The brake system is filled with MIL-H-5606 (petroleum base) hydraulic brake fluid. The fluid level should be checked periodically or at every 50-hour inspection and replenished when necessary. The brake reservoir is located on the fire wall in the engine compartment. If the entire system must be refilled, fill with fluid under pressure from the brake end of the system. This will eliminate air from the system.

No adjustment of the brake clearances is necessary. If after extended service brake blocks become excessively worn, they should be replaced with new segments.

8.15 LANDING GEAR SERVICE

The main landing gears use 6.00 x 6 wheels and the nose gear carries a 5.00 x 5 wheel. All three tires are four-ply rating, type III tires with tubes. (Refer to paragraph 8.23).

Wheels are removed by taking off the hub cap, cotter pin, axle nut, and the two bolts holding the brake segment in place. Mark tire and wheel for reinstallation; then dismount by deflating the tire, removing the three through-bolts from the wheel and separating the wheel halves.

Landing gear oleos should be serviced according to the instructions on the units. The main oleos should be extended under normal static load until $4.50 \pm .25$ inches of oleo piston tube is exposed, and the nose gear should show $3.25 \pm .25$ inches. Should the strut exposure be below that required, it should be determined whether air or oil is required by first raising the airplane on jacks. Depress the valve core to allow air to escape from the strut housing chamber. Remove the filler plug and slowly raise the strut to full compression. If the strut has sufficient fluid, it will be visible up to the bottom of the filler plug hole and will then require only proper inflation.

Should hydraulic fluid be below the bottom of the filler plug hole, fluid should be added. Replace the plug with valve core removed; attach a clear plastic hose to the valve stem of the filler plug and submerge the other end in a container of hydraulic fluid. Fully compress and extend the strut several times, thus drawing fluid from the container and expelling air from the strut chamber. To allow fluid to enter the bottom chamber of the main gear strut housing, the torque link assembly must be disconnected to let the strut be extended a minimum of 10 inches (the nose gear torque links need not be disconnected). Do not allow the strut to extend more than 12 inches. When air bubbles cease to flow through the hose, compress the strut fully and again check fluid level. Reinstall the valve core and filler plug, and the main gear torque links, if disconnected.

With fluid in the strut housing at the correct level, attach a strut pump to the air valve and with the airplane on the ground, inflate the oleo strut to the correct height.

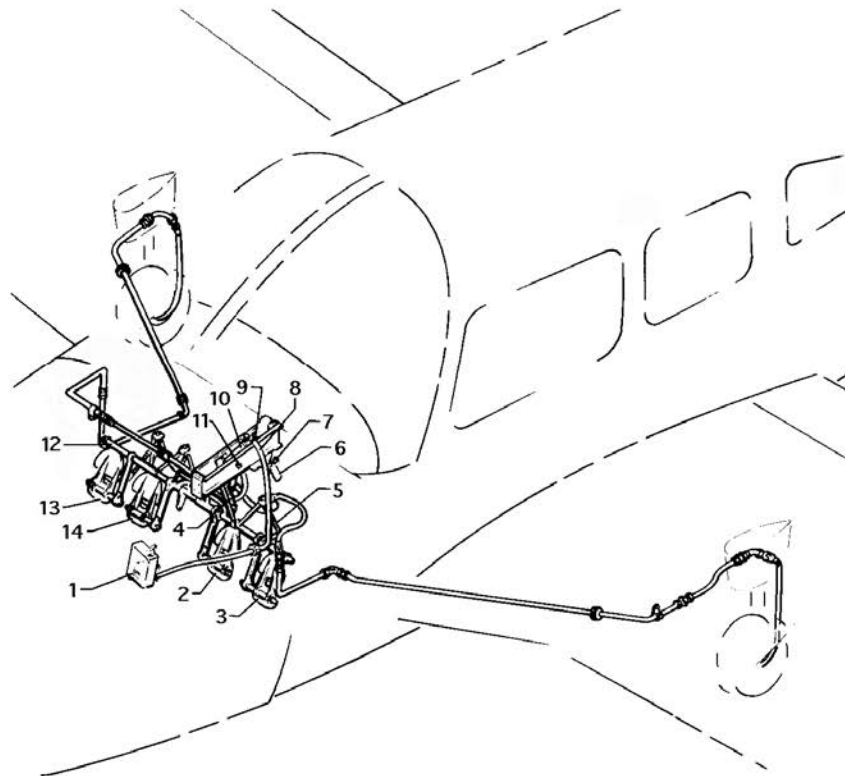

1. BRAKE RESERVOIR
2. RIGHT BRAKE AND RUDDER PEDAL
3. LEFT BRAKE AND RUDDER PEDAL
4. RIGHT BRAKE CYLINDER
5. LEFT BRAKE CYLINDER
6. BRAKE HANDLE
7. HANDLE RELEASE BUTTON
8. LINE, INLET
9. CLEVIS PIN
10. MASTER CYLINDER ASSEMBLY
11. BOLT ASSEMBLY
12. TORQUE TUBE
13. COPILOT'S RIGHT BRAKE AND RUDDER PEDAL
14. COPILOT'S LEFT BRAKE AND RUDDER PEDAL

BRAKE SYSTEM

Figure 8-1

In jacking the aircraft for landing gear or other service, two hydraulic jacks and a tail stand should be used. At least 250 pounds of ballast should be placed on the base of the tail stand before the airplane is jacked up. The hydraulic jacks should be placed under the jack points on the bottom of the wing and the airplane jacked up until the tail skid is at the right height to attach the tail stand. After the tail stand is attached and the ballast added, jacking may be continued until the airplane is at the height desired.

8.17 PROPELLER SERVICE

The spinner and backing plate should be frequently cleaned and inspected for cracks. Before each flight the propeller should be inspected for nicks, scratches, and corrosion. If found, they should be repaired as soon as possible by a rated mechanic, since a nick or scratch causes an area of increased stress which can lead to serious cracks or the loss of a propeller tip. The back face of the blades should be painted when necessary with flat black paint to retard glare. To prevent corrosion, the surface should be cleaned and waxed periodically.

8.19 OIL REQUIREMENTS

The oil capacity of the engine is 8 quarts, and the minimum safe quantity is 2 quarts. It is recommended that the oil be drained and renewed every 50 hours and sooner under unfavorable operating conditions. Full flow cartridge type oil filters should be replaced each 50 hours of operation. The interval between oil and oil filter change is not to exceed four (4) months. The following grades are recommended for the specified temperatures:

<u>Average Ambient Temperature</u>	<u>MIL-L-6082B SAE Grade</u>	<u>MIL-L-22851 Ashless Dispersant SAE Grades</u>
All Temperatures	--	15W-50 or 20W-50
Above 80°F	60	60
Above 60°F	50	40 or 50
30°F to 90°F	40	40
0°F to 70°F	30	30, 40 or 20W-40
Below 10°F	20	30 or 20W-30

When operating temperatures overlap indicated ranges, use the lighter grade oil.

NOTE

Refer to the latest issue of Lycoming Service Instruction 1014 (Lubricating Oil Recommendations) for further information.

8.21 FUEL SYSTEM

(a) Servicing Fuel System

At every 50-hour inspection, the fuel screens in the strainer, in the electric fuel pump, and at the carburetor inlet must be cleaned.

(b) Fuel Requirements (AVGAS ONLY)

The minimum aviation grade fuel for the PA-28-161 is 100. Since the use of lower grades can cause serious engine damage in a short period of time, the engine warranty is invalidated by the use of lower octanes.

Whenever 100 or 100LL grade fuel is not available, commercial grade 100/130 should be used. (See Fuel Grade Comparison Chart). Refer to the latest issue of Lycoming Service Instruction No. 1070 for additional information.

A summary of the current grades as well as the previous fuel designations is shown in the following chart:

FUEL GRADE COMPARISON CHART

Previous Commercial Fuel Grades (ASTM-D910)			Current Commercial Fuel Grades (ASTM-D910-75)			Current Military Fuel Grades (MIL-G-5572F)		
Grade	Color	Max. TEL ml/U.S. gal	Grade	Color	Max. TEL ml/U.S. gal	Grade	Color	Max. TEL ml/U.S. gal
80/87	red	0.5	80	red	0.5	80/87	red	0.5
91/96	blue	2.0	*100LL	blue	2.0	none	none	none
100/130	green	3.0	100	green	**3.0	100/130	blue	2.0
115/145	purple	4.6	none	none	none	115/145	purple	4.6

* -Grade 100LL fuel in some overseas countries is currently colored green and designated as "100L".

** -Commercial fuel grade 100 and grade 100/130 having TEL content of up to 4 ml/U.S. gallon are approved for use in all engines certificated for use with grade 100/130 fuel.

The operation of the aircraft is approved with an anti-icing additive in the fuel. When anti-icing additive is used, it must meet the specification MIL-I-27686, must be uniformly blended with the fuel while refueling, must not exceed .15% by volume of the refueled quantity, and to ensure its effectiveness should be blended at not less than .10% by volume. One and one half liquid ozs. per ten gallons of fuel would fall within this range. A blender supplied by the additive manufacturer should be used. Except for the information contained in this section, the manufacturer's mixing or blending instructions should be carefully followed.

CAUTIONS

Assure that the additive is directed into the flowing fuel stream. The additive flow should start after and stop before the fuel flow. Do not permit the concentrated additive to come in contact with the aircraft painted surfaces or the interior surfaces of the tanks.

Some fuels have anti-icing additives pre- blended in the fuel at the refinery, so no further blending should be performed.

Fuel additive cannot be used as a substitute for preflight draining of the fuel system drains.

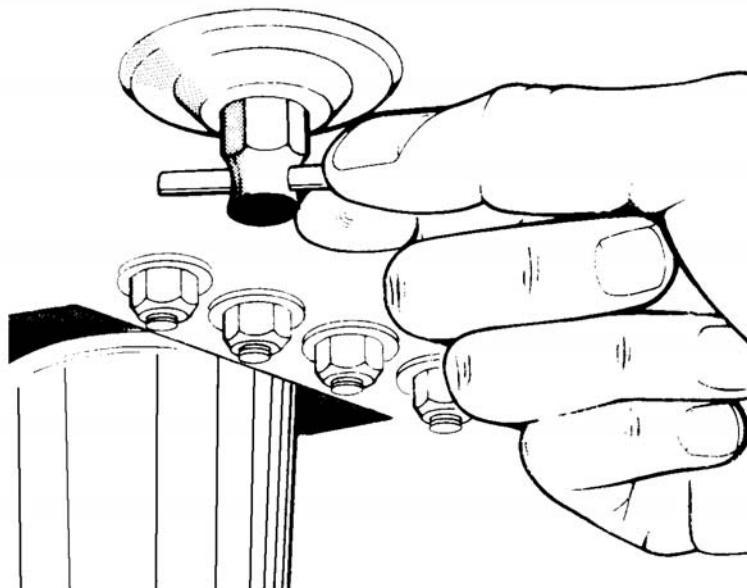

FUEL DRAIN

Figure 8-3

(c) Filling Fuel Tanks

Observe all required precautions for handling gasoline. Fill the fuel tanks through the filler located on the forward slope of the wing. Each wing holds a maximum of 25 U.S. Gallons. When using less than the standard 50 gallon capacity, fuel should be distributed equally between each tank. There is approximately 17 gallons in the fuel tank when fuel level is even with bottom of filler neck indicator.

(d) Draining Fuel Strainer, Sumps and Lines

The fuel tank sumps and strainer should be drained daily prior to the first flight and after refueling to avoid the accumulation of contaminants such as water or sediment and for proper fuel.

Each fuel tank is equipped with an individual quick drain located at the lower inboard rear corner of the tank. The fuel strainer is equipped with a quick drain located on the front lower corner of the fire wall. Each of the fuel tank sumps should be drained first. Then the fuel strainer should be drained twice, once with the fuel selector valve on each tank. Each time fuel is drained, sufficient fuel should be allowed to flow to ensure removal of contaminants. This fuel should be collected in a suitable container, examined for contaminants, proper fuel and then discarded.

CAUTIONS

When draining any amount of fuel, care should be taken to ensure that no fire hazard exists before starting the engine.

After draining, each quick drain should be checked to make sure it has closed completely and is not leaking.

(e) Draining Fuel System

The bulk of the fuel may be drained from the system by opening valve at the inboard end of each fuel tank. Push up on the arms of the drain valve and turn counterclockwise to hold the drain open. The remaining fuel in the system may be drained through the filter bowl. Any individual tank may be drained by closing the selector valve and then draining the desired tank.

8.23 TIRE INFLATION

For maximum service from the tires, keep them inflated to the proper pressures - 30 psi for the nose gear and 24 psi for the main gear. All wheels and tires are balanced before original installation, and the relationship of tire, tube and wheel should be maintained upon reinstallation. Unbalanced wheels can cause extreme vibration in the landing gear; therefore, in the installation of new components, it may be necessary to rebalance the wheels with the tires mounted. When checking tire pressure, examine the tires for wear, cuts, bruises, and slippage.

8.25 BATTERY SERVICE

Access to the 24-volt battery is obtained by raising upper right cowl which provides access to the battery box, which is mounted on the forward right face of the fire wall. The sealed battery box has a leak proof vent system with a vent tube which vents gases and acid fumes from the battery manifold.

The battery should be checked for proper fluid level. DO NOT fill the battery above the baffle plates. DO NOT fill the battery with acid - use only water. A hydrometer check will determine the percent of charge in the battery.

If the battery is not up to charge, recharge starting at a 4 amp rate and finishing with a 2 amp rate. Quick charges are not recommended.

8.27 CLEANING

(a) Cleaning Engine Compartment

Before cleaning the engine compartment, place a strip of tape on the magneto vents to prevent any solvent from entering these units.

- (1) Place a large pan under the engine to catch waste.
- (2) With the engine cowling removed, spray or brush the engine with solvent or a mixture of solvent and degreaser. In order to remove especially heavy dirt and grease deposits, it may be necessary to brush areas that were sprayed.

CAUTION

Do not spray solvent into the alternator, vacuum pump, starter, or air intakes.

- (3) Allow the solvent to remain on the engine from five to ten minutes. Then rinse the engine clean with additional solvent and allow it to dry.

CAUTION

Do not operate the engine until excess solvent has evaporated or otherwise been removed.

- (4) Remove the protective tape from the magnetos.
- (5) Lubricate the controls, bearing surfaces, etc., in accordance with the Lubrication Chart in the PA-28-161 Service Manual.

(b) Cleaning Landing Gear

Before cleaning the landing gear, place a plastic cover or similar material over the wheel and brake assembly.

- (1) Place a pan under the gear to catch waste.
- (2) Spray or brush the gear area with solvent or a mixture of solvent and degreaser, as desired. Where heavy grease and dirt deposits have collected, it may be necessary to brush areas that were sprayed, in order to clean them.
- (3) Allow the solvent to remain on the gear from five to ten minutes. Then rinse the gear with additional solvent and allow to dry.
- (4) Remove the cover from the wheel and remove the catch pan.
- (5) Lubricate the gear in accordance with the Lubrication Chart in the PA-28-161 Service Manual.

(c) Cleaning Exterior Surfaces

The airplane should be washed with a mild soap and water. Harsh abrasives or alkaline soaps or detergents could make scratches on painted or plastic surfaces or could cause corrosion of metal. Cover areas where cleaning solution could cause damage. To wash the airplane, use the following procedure:

- (1) Flush away loose dirt with water.
- (2) Apply cleaning solution with a soft cloth, a sponge or a soft bristle brush.
- (3) To remove exhaust stains, allow the solution to remain on the surface longer.
- (4) To remove stubborn oil and grease, use a cloth dampened with naphtha.
- (5) Rinse all surfaces thoroughly.
- (6) Any good automotive wax may be used to preserve painted surfaces. Soft cleaning cloths or a chamois should be used to prevent scratches when cleaning or polishing. A heavier coating of wax on the leading surfaces will reduce the abrasion problems in these areas.

(d) Cleaning Windshield and Windows

- (1) Remove dirt, mud and other loose particles from exterior surfaces with clean water.
- (2) Wash with mild soap and warm water or with aircraft plastic cleaner. Use a soft cloth or sponge in a straight back and forth motion. Do not rub harshly.
- (3) Remove oil and grease with a cloth moistened with kerosene.

CAUTION

Do not use gasoline, alcohol, benzene, carbon tetrachloride, thinner, acetone, or window cleaning sprays.

- (4) After cleaning plastic surfaces, apply a thin coat of hard polishing wax. Rub lightly with a soft cloth. Do not use a circular motion.
- (5) A severe scratch or mar in plastic can be removed by rubbing out the scratch with jeweler's rouge. Smooth both sides and apply wax.

(e) Cleaning Headliner, Side Panels and Seats

- (1) Clean headliner, side panels, and seats with a stiff bristle brush, and vacuum where necessary.
- (2) Soiled upholstery, except leather, may be cleaned with a good upholstery cleaner suitable for the material. Carefully follow the manufacturer's instructions. Avoid soaking or harsh rubbing.

CAUTION

Solvent cleaners require adequate ventilation.

- (3) Leather should be cleaned with saddle soap or a mild hand soap and water.

(f) Cleaning Carpets

To clean carpets, first remove loose dirt with a whisk broom or vacuum. For soiled spots and stubborn stains use a nonflammable dry cleaning fluid. Floor carpets may be removed and cleaned like any household carpet.

8.29 COLD WEATHER OPERATION

For cold weather operation a winterization plate is installed on the inlet opening of the oil cooler. This plate should be installed whenever the ambient temperature reaches 50° F or less. The plate should be removed and stored in the cockpit when the ambient temperature exceeds 50° F.

It is recommended that an optional Engine Breather Tube Winterization Kit be installed for cold weather operation. This kit is available through your Piper Dealer/Distributor.

**SECTION 8
HANDLING, SERV & MAINT**

**PIPER AIRCRAFT CORPORATION
PA-28-161, WARRIOR III**

THIS PAGE INTENTIONALLY LEFT BLANK

**REPORT: VB-1565
8-20**

ISSUED: JULY 1, 1994

TABLE OF CONTENTS
SECTION 9
SUPPLEMENTS

Paragraph No.		Page No.
9.1	General	9-1
1	Auxiliary Vacuum System.....(4 pages)	9-3

THIS PAGE INTENTIONALLY LEFT BLANK

REPORT: VB-1565

9-ii

**SECTION 9
SUPPLEMENTS**

9.1 GENERAL

This section provides information in the form of Supplements which are necessary for efficient operation of the airplane when equipped with one or more of the various optional systems and equipment not provided with the standard airplane.

All of the Supplements provided by this section are FAA Approved and consecutively numbered as a permanent part of this Handbook. The information contained in each Supplement applies only when the related equipment is installed in the airplane.

THIS PAGE INTENTIONALLY LEFT BLANK

PILOT'S OPERATING HANDBOOK
AND
FAA APPROVED AIRPLANE FLIGHT MANUAL

SUPPLEMENT NO. 1
FOR
AUXILIARY VACUUM SYSTEM

This supplement must be attached to the Pilot's Operating Handbook and FAA Approved Airplane Flight Manual when the Piper Auxiliary Vacuum System is installed in accordance with Piper Drawing 87774-2. The information contained herein supplements or supersedes the Pilot's Operating Handbook and FAA Approved Airplane Flight Manual only in those areas listed herein. For limitations, procedures and performance information not contained in this supplement, consult the Pilot's Operating Handbook and FAA Approved Airplane Flight Manual.

FAA APPROVED:

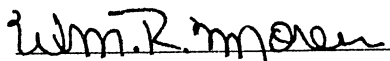

WILLIAM R. MOREU

D.O.A. NO. SO-1

PIPER AIRCRAFT CORPORATION

VERO BEACH, FLORIDA

DATE OF APPROVAL:

1 JULY 1994

ISSUED: JULY 1, 1994

REPORT: VB-1565

9-3

SECTION 1 - GENERAL

This supplement supplies information necessary for the operation of the airplane when the optional Piper Auxiliary Vacuum System is installed. The information contained within this supplement is to be used in conjunction with the complete handbook.

SECTION 2 - LIMITATIONS

1. The auxiliary vacuum system is limited to standby function only. Take off with the engine driven dry air pump inoperative is not approved.
2. Discontinue flight in instrument meteorological conditions (IMC) if vacuum pressure falls below 4.8 In. Hg.
3. The auxiliary pump/motor assembly and elapsed time indicator must be removed from service after 500 hours accumulated operating time or 10 years, whichever occurs first.

SECTION 3 - EMERGENCY PROCEDURES

LOSS OF VACUUM SUCTION - Vacuum inop (VAC) annunciator and VAC OFF warning lamp lit

1. Vacuum gaugeCheck to verify inoperative pump. If vacuum gauge reads below 4.5 inches of mercury:
2. Auxiliary vacuum switchPress AUX ON.
3. Verify vacuum pressure of 4.8 to 5.2 inches of mercury.
4. Verify VAC inop annunciator and VAC OFF lights go out.

CAUTION

Compass error may exceed 10 when auxiliary vacuum system is in operation.

5. Electrical loadMonitor
 - a. Verify alternator capacity is not being exceeded.
 - b. If required, turn off nonessential electrical equipment.

SECTION 4 - NORMAL PROCEDURES

- A. Preflight Check.
1. Set battery switch on and verify that VAC OFF lamp lights.

NOTE

Due to electrical power requirement of the auxiliary vacuum pump it is suggested that the engine be operating while making the following checks.

2. Turn on auxiliary vacuum pump on and verify AUX ON light is illuminated and electrical load is approximately 15 amps on ammeter.
 3. Turn off auxiliary vacuum pump and verify AUX ON light goes out.
- B. Inflight Check - Prior to entering instrument flight conditions.
1. Turn off non-essential electrical equipment.
 2. Turn on auxiliary vacuum pump and verify AUX ON light illuminated and electrical load is approximately 11 amps on ammeter.
 3. Turn off auxiliary vacuum pump and verify AUX ON light goes out.

NOTE

For maximum service life, avoid continuous non-emergency operation of the auxiliary vacuum pump.

SECTION 5 - PERFORMANCE

No change.

SECTION 6 - WEIGHT & BALANCE

Factory installed optional equipment is included in the licensed weight and balance data in section 6 of the Pilot's Operating Handbook.

SECTION 7 - DESCRIPTION AND OPERATION

The auxiliary dry air pump system provides an independent back-up source of pneumatic power to operate the gyro flight instruments in the event the engine driven air pump fails.

The auxiliary pump is mounted on the forward side of the firewall and connects to the primary system at a manifold downstream of the vacuum regulator. Isolation of the primary and auxiliary systems from each other is accomplished by check valves on each side of the manifold. The primary system vacuum switch is located on the regulator and senses vacuum supplied to the gyros.

A control switch (labeled AUX VAC) for the auxiliary pump system is located on the right side of the instrument panel near the vacuum suction gage.

The switch button incorporates two annunciator light sections labeled VAC OFF and AUX ON. The VAC OFF section is controlled by a vacuum switch in the primary pneumatic system and illuminates an amber light when the engine driven pump is inoperative or when the system vacuum falls below the switch activation level. The AUX ON section is controlled by a vacuum switch on the manifold and illuminates a blue light when the auxiliary pump is operating and creating a vacuum in the system. When the auxiliary pump is activated at high altitude, or if the system has developed air leaks, the AUX ON light may fail to illuminate. This indicates that the system vacuum is still below the AUX ON switch activation level even though the auxiliary pump is operating. The annunciator lights do not incorporate a press-to-test feature, if the lights do not illuminate as expected, check for burned out lamps, replace with MS25237-330 bulbs and retest the system.

System electrical protection is provided by a 20 amp circuit breaker in the pump motor circuit and a 5 amp circuit breaker in the annunciator light circuit. The breakers are mounted on the circuit breaker panel.

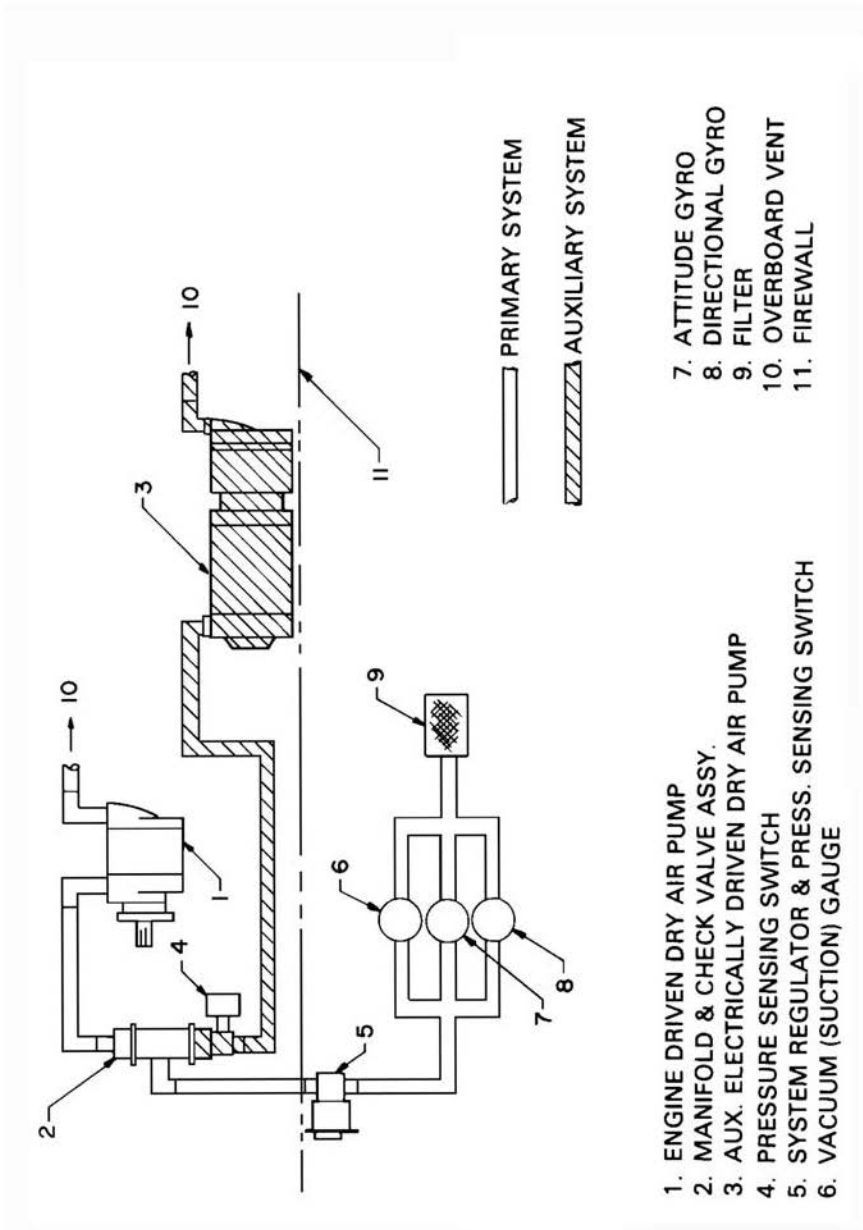

ISSUED: JULY 1, 1994

REPORT: VB-1565
 9-7

THIS PAGE INTENTIONALLY LEFT BLANK

TABLE OF CONTENTS
SECTION 10
OPERATING TIPS

Paragraph No.		Page No.
10.1	General	10-1
10.3	Operating Tips	10-1

THIS PAGE INTENTIONALLY LEFT BLANK

**SECTION 10
OPERATING TIPS**

10.1 GENERAL

This section provides operating tips of particular value in the operation of the WARRIOR III.

10.3 OPERATING TIPS

- (a) Learn to trim for takeoff so that only a very light back pressure on the control wheel is required to lift the airplane off the ground.
- (b) The best speed for takeoff is about 55 KIAS under normal conditions. Trying to pull the airplane off the ground at too low an airspeed decreases the controllability of the airplane in the event of engine failure.
- (c) Flaps may be lowered at airspeeds up to 103 KIAS. To reduce flap operating loads, it is desirable to have the airplane at a slower speed before extending the flaps. The flap step will not support weight if the flaps are in any extended position. The flaps must be placed in the "UP" position before they will lock and support weight on the step.
- (d) Before attempting to reset any circuit breaker, allow a two to five minute cooling off period.
- (e) Before starting the engine, check that all radio switches, light switches and the pitot heat switch are in the off position so as not to create an overloaded condition when the starter is engaged.
- (f) Anti-collision lights should not be operating when flying through cloud, fog or haze, since the reflected light can produce spatial disorientation. Strobe lights should not be used in close proximity to the ground such as during taxiing, takeoff or landing.

**SECTION 10
OPERATING TIPS**

**PIPER AIRCRAFT CORPORATION
PA-28-161, WARRIOR III**

- (g) The rudder pedals are suspended from a torque tube which extends across the fuselage. The pilot should become familiar with the proper positioning of his feet on the rudder pedals so as to avoid interference with the torque tube when moving the rudder pedals or operating the toe brakes.
- (h) In an effort to avoid accidents, pilots should obtain and study the safety related information made available in FAA publications such as regulations, advisory circulars, Aviation News, AIM and safety aids.
- (i) Prolonged slips and skids which result in excess of 2000 ft. of altitude loss, or other radical or extreme maneuvers which could cause uncovering of the fuel outlet must be avoided as fuel flow interruption may occur when the tank being used is not full.
- (j) Hand starting of the engine is not recommended, however, should hand starting of the engine be required, only experienced personnel should attempt this procedure. The magneto selector should be placed to LEFT during the starting procedures to reduce the probability of "kick back." Place the ignition switch to BOTH position after the engine has started.